

**G  
N  
K  
V**

# TECHNICAL Practice

**TELECOM SOLUTIONS FOR THE 21ST CENTURY**

## E-75 Series

*Double Gang Video  
Entry Phones with Built-In  
Proximity Card Reader*

February 8, 2010

## Video Entry Phones with Built-In Proximity Card Reader



**E-75-SS**  
"Brushed Stainless Steel" (similar to brushed nickel) Optional **VE-5x5** surface mount box shown (not included)



**E-75-BN**  
"Oil Rubbed Bronze"  
(satin dark brown powder paint with fine copper metallic)



**E-75-PB**  
"Polished Brass"  
(with clear gloss powder paint to prevent tarnishing)



**E-75-WH**  
"Satin White"  
(satin white powder paint)



**E-75-BK**  
"Satin Black"  
(fine texture satin black powder paint)

The **E-75** Series Video Entry phones are compact, weather and vandal resistant speaker phones designed to provide two-way hands-free audio communication and color composite video of who is at your door or gate. The **E-75** also includes a built-in 125KHz HID compatible proximity card reader. The card reader outputs industry standard 26-bit Wiegand data, allowing it to be used with a **Viking ES-1** door controller or any controller compatible with 26-bit Wiegand format. The **E-75**'s compact size allows it to be mounted in a standard double gang electrical box. The **E-75** is available in five different attractive finishes to match your door hardware, light fixtures, etc. Replacement **E-75** faceplates (**PNL75**) can be purchased separately and are available in all five standard finishes. The **E-75** entry phones can share a single phone line with house or small business telephones when used with a **Viking** model **C-200**, **C-250** or **C-2000B** Entry Phone controller. The **E-75** entry phones can also be connected to an unused analog station port (programmed for ring down) on a phone system or connected directly to a telephone line when used with a **Viking** model **K-1900-5** auto dialer. The **E-75** features a built-in high resolution color video camera, a built-in proximity card reader, microphone and speaker volume controls, selectable auto answer for monitoring and intelligent call progress detection for automatic hang-up when the call is completed. For outdoor environments or corrosive atmospheres, the **E-75** is available with Enhanced Weather Protection (EWP), see DOD# 859.

## Features

- Built-in 125KHz HID compatible 26-bit Wiegand proximity card reader with LED and beep card read confirmation and EWP board protection
- Built-in high resolution color video camera with wide viewing, tilt/swivel adjustments, and wide operating temperature of -30° F to 150° F
- Audio and video transmission on one CAT5E cable (see page 5)
- **Compact size:** Front panel is the size of a typical double gang mid-size wall plate
- **Mounting:** Flush mounts in a double gang electrical box (2.25" deep x 3.7" wide x 2.84" tall minimum) or surface mounts in a Viking model **VE-5x5** (not included, see DOD# 424) for mounting to a wall, post or VE-GNP Gooseneck Pedestal (EWP recommended)
- **Available in 5 standard faceplate finishes:** Brushed Stainless Steel, Oil Rubbed Bronze, Polished Brass, Satin Black and Satin White
- **PNL-75 faceplates:** Replacement faceplates with matching screws available in all five standard finishes
- **Features:** Mylar speaker, faceplate gasket, mic and speaker gasket, internally sealed (IP67) push button switch, self draining mic mount and UV stable weather resistant powder coating (excludes **E-75-SS** stainless steel faceplate)
- **Vandal Resistant Features:** 16 gauge polished brass or 18 gauge stainless steel faceplate, stainless steel push button, stainless steel speaker screen, scratch resistant powder coating, hex drive mounting screws
- **Optional Enhanced Weather Protection (EWP, recommended for outdoor applications) Features:** Urethane potted circuit board, internally sealed POTS and dip switches, potted microphone and push-button switch, etc.
- Blue LED helps locate the push button, indicate ringing and off-hook
- Programmable Intelligent call progress detection for automatic hang-up on CPC, silence, busy signal, or time out

## Applications

- Door or gate communication, business delivery entrances
- Use with a **Viking C-200** or **C-250** to control one **E-75** on a single phone line
- Use with a **Viking C-2000B** to control 1 to 4 **E-75**'s and door/gate control on a single phone line
- Use with a **Viking ES-1** for proximity card reader door control
- Provide unique front and back door chimes and paging when used with a **Viking SLP-1** or **SLP-4** and **C-2000B**
- Residential, commercial and industrial door security
- Use with a **Viking K-1900-5** for automatic speed dialing on telephone lines or analog PABX/KSU station ports
- Use on any analog PABX station port with programmable ringdown capability

Phone...715.386.8861

[info@vikingelectronics.com](mailto:info@vikingelectronics.com)

<http://www.vikingelectronics.com>

## Specifications

**Dimensions:** Faceplate: 123.8mm x 125.4mm x 4.3mm (4.875" x 4.938" x 0.171"), Phone: 72mm x 46mm x 42mm (2.84" x 1.8" x 1.65")

**Shipping Weight:** 0.55 kg (1.2 lbs)

**Operating Temperature:** -34° C to 65° C (-30° F to 150° F)

**Connections:** (2) gel-filled butt connectors (3M Scotchlok UR2)

(See page 2 for complete specifications)

## IF YOU HAVE A PROBLEM WITH A VIKING PRODUCT, PLEASE CONTACT: VIKING TECHNICAL SUPPORT AT (715) 386-8666

Our Technical Support Department is available for assistance Monday 8am - 4pm and Tuesday through Friday 8am - 5pm central time. So that we can give you better service, before you call please:

1. Know the model number, the serial number and what software version you have (see serial label).
2. Have your Technical Practice in front of you.
3. It is best if you are on site.

### RETURNING PRODUCT FOR REPAIR

The following procedure is for equipment that needs repair:

1. Customer must contact Viking's Technical Support Department at 715-386-8666 to obtain a Return Authorization (RA) number. The customer MUST have a complete description of the problem, with all pertinent information regarding the defect, such as options set, conditions, symptoms, methods to duplicate problem, frequency of failure, etc.
2. Packing: Return equipment in original box or in proper packing so that damage will not occur while in transit. Static sensitive equipment such as a circuit board should be in an anti-static bag, sandwiched between foam and individually boxed. All equipment should be wrapped to avoid packing material lodging in or sticking to the equipment. Include ALL parts of the equipment. C.O.D. or freight collect shipments cannot be accepted. Ship cartons prepaid to:  
**Viking Electronics, 1531 Industrial Street, Hudson, WI 54016**
3. Return shipping address: Be sure to include your return shipping address inside the box. We cannot ship to a PO Box.
4. RA number on carton: In large printing, write the R.A. number on the outside of each carton being returned.

### RETURNING PRODUCT FOR EXCHANGE

The following procedure is for equipment that has failed out-of-box (within 10 days of purchase):

1. Customer must contact Viking's Technical Support at 715-386-8666 to determine possible causes for the problem. The customer MUST be able to step through recommended tests for diagnosis.
2. If the Technical Support Product Specialist determines that the equipment is defective based on the customer's input and troubleshooting, a Return Authorization (R.A.) number will be issued. This number is valid for fourteen (14) calendar days from the date of issue.
3. After obtaining the R.A. number, return the approved equipment to your distributor, referencing the R.A. number. Your distributor will then replace the product over the counter at no charge. The distributor will then return the product to Viking using the same R.A. number.
4. **The distributor will NOT exchange this product without first obtaining the R.A. number from you. If you haven't followed the steps listed in 1, 2 and 3, be aware that you will have to pay a restocking charge.**

### LIMITED WARRANTY

Viking warrants its products to be free from defects in the workmanship or materials, under normal use and service, for a period of one year from the date of purchase from any authorized Viking distributor or 18 months from the date manufactured, whichever ever is greater. If at any time during the warranty period, the product is deemed defective or malfunctions, return the product to Viking Electronics, Inc., 1531 Industrial Street, Hudson, WI, 54016. Customer must contact Viking's Technical Support Department at 715-386-8666 to obtain a Return Authorization (R.A.) number.

This warranty does not cover any damage to the product due to lightning, over voltage, under voltage, accident, misuse, abuse, negligence or any damage caused by use of the product by the purchaser or others.

**NO OTHER WARRANTIES. VIKING MAKES NO WARRANTIES RELATING TO ITS PRODUCTS OTHER THAN AS DESCRIBED ABOVE AND DISCLAIMS ANY EXPRESS OR IMPLIED WARRANTIES OR MERCHANTABILITY OR FITNESS FOR ANY PARTICULAR PURPOSE.**

**EXCLUSION OF CONSEQUENTIAL DAMAGES.** VIKING SHALL NOT, UNDER ANY CIRCUMSTANCES, BE LIABLE TO PURCHASER, OR ANY OTHER PARTY, FOR CONSEQUENTIAL, INCIDENTAL, SPECIAL OR EXEMPLARY DAMAGES ARISING OUT OF OR RELATED TO THE SALE OR USE OF THE PRODUCT SOLD HEREUNDER.

**EXCLUSIVE REMEDY AND LIMITATION OF LIABILITY.** WHETHER IN AN ACTION BASED ON CONTRACT, TORT (INCLUDING NEGLIGENCE OR STRICT LIABILITY) OR ANY OTHER LEGAL THEORY, ANY LIABILITY OF VIKING SHALL BE LIMITED TO REPAIR OR REPLACEMENT OF THE PRODUCT, OR AT VIKING'S OPTION, REFUND OF THE PURCHASE PRICE AS THE EXCLUSIVE REMEDY AND ANY LIABILITY OF VIKING SHALL BE SO LIMITED.

IT IS EXPRESSLY UNDERSTOOD AND AGREED THAT EACH AND EVERY PROVISION OF THIS AGREEMENT WHICH PROVIDES FOR DISCLAIMER OF WARRANTIES, EXCLUSION OF CONSEQUENTIAL DAMAGES, AND EXCLUSIVE REMEDY AND LIMITATION OF LIABILITY, ARE SEVERABLE FROM ANY OTHER PROVISION AND EACH PROVISION IS A SEPARABLE AND INDEPENDENT ELEMENT OF RISK ALLOCATION AND IS INTENDED TO BE ENFORCED AS SUCH.

### FCC REQUIREMENTS

This equipment complies with Part 68 of the FCC rules and the requirements adopted by the ACTA. Inside the front panel of this equipment is a label that contains, among other information, a product identifier in the format US:AAAEQ#TXXXX. If requested, this number must be provided to the telephone company.

The REN is used to determine the number of devices that may be connected to a telephone line. Excessive REN's on a telephone line may result in the devices not ringing in response to an incoming call. In most but not all areas, the sum of the REN's should not exceed five (5.0). To be certain of the number of devices that may be connected to a line, as determined by the total REN's, contact the local telephone company. For products approved after July 23, 2001, the REN for this product is part of the product identifier that has the format US:AAAEQ#TXXXX. The digits represented by # are the REN without a decimal point (e.g., .03 is a REN of 0.3). For earlier products, the REN is separately shown on the label.

The plug used to connect this equipment to the premises wiring and telephone network must comply with the applicable FCC Part 68 rules and requirements adopted by the ACTA. If your home has specially wired alarm equipment connected to the telephone line, ensure the installation of this E-75 does not disable your alarm equipment. If you have questions about what will disable alarm equipment, consult your telephone company or a qualified installer.

If the E-75 causes harm to the telephone network, the telephone company will notify you in advance that temporary discontinuance of service may be required. But if advance notice isn't practical, the telephone company will notify the customer as soon as possible. Also, you will be advised of your right to file a complaint with the FCC if you believe it is necessary.

The telephone company may make changes in its facilities, equipment, operations, or procedures that could affect the operation of the equipment. If this happens, the telephone company will provide advance notice in order for you to make

the necessary modifications to maintain uninterrupted service.

If trouble is experienced with the E-75, for repair or warranty information, please contact:

**Viking Electronics, Inc., 1531 Industrial Street, Hudson, WI 54016 (715) 386-8666**

If the equipment is causing harm to the telephone network, the telephone company may request that you disconnect the equipment until the problem is resolved.

Connection to Party Line Service is subject to State Tariffs. Contact the state public utility commission, public service commission or corporation commission for information.

**WHEN PROGRAMMING EMERGENCY NUMBERS AND (OR) MAKING TEST CALLS TO EMERGENCY NUMBERS:**

Remain on the line and briefly explain to the dispatcher the reason for the call. Perform such activities in the off-peak hours, such as early morning or late evenings.

It is recommended that the customer install an AC surge arrester in the AC outlet to which this device is connected. This is to avoid damaging the equipment caused by local lightning strikes and other electrical surges.

### PART 15 LIMITATIONS

This equipment has been tested and found to comply with the limits for a Class A digital device, pursuant to Part 15 of the FCC Rules. These limits are designed to provide reasonable protection against harmful interference when the equipment is operated in a commercial environment. This equipment generates, uses, and can radiate radio frequency energy and, if not installed and used in accordance with the instruction manual, may cause harmful interference to radio communications. Operation of this equipment in a residential area is likely to cause harmful interference in which case the user will be required to correct the interference at his own expense.

## Specifications

### Entry Phone Specifications

**Power:** Telephone line powered. Minimum 18V DC talk battery voltage with a minimum loop current of 20mA. Loop current may be boosted on low current lines with a Viking model **TBB-1B** Talk Battery Booster (see **DOD# 632**).

**Dimensions:** Faceplate: 123.8mm x 125.4mm x 4.3mm (4.875" x 4.938" x 0.17"), Phone: 72mm x 46mm x 42mm (2.84" x 1.8" x 1.65")

**Speaker Volume:** Approximately 62db maximum @ 1m

**Ring Voltage:** 25V AC RMS minimum (for auto answer)

**CPC Disconnect Time:** 300ms minimum

**REN:** 0.8A

### Camera Specifications

**Power:** 3.5-6V DC regulated 150mA (5V DC regulated adapter included)

**Image Sensor:** 1/4" color CMOS

**Video Output:** 1 VP-P composite, NTSC, 75 ohms

**Resolution:** 420 lines (640 x 480 @ 30fps / 307,200 pixels)

**Sensitivity:** 0.26 LUX (20 IRE) F 2.0

**Lens:** 3.4mm, pinhole 70° FOV (Field of View)

**Tilt/Swivel Adjustment:** Vertical +/- 20°, horizontal

+/- 30° (see **Diagram A**)

**IR Compatibility:** This camera is equipped with an OLP (Optical Low Pass) filter to maintain correct video color in outside applications. The standard camera is **NOT** compatible with IR illuminators. If IR illumination is required, you will need to replace the existing camera with a Viking model **VCAM-11R**, see **DOD# 190**.

**Maximum Wire Run Length:** 750 ft with

\*RG59/RG6 for video and CAT5 for power (3 pairs) and entry phone audio (1 pair).

150 ft with CAT5E for video, power and entry phone audio (longer video runs are possible by using video balun transceivers, see **Installation** section F, page 5).

**Diagram A**  
Camera Field of View:

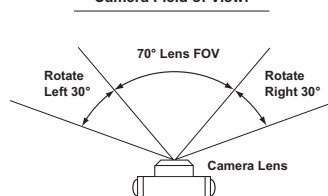

### Entry Phone / Camera Specifications

**Operating Temperature:** -34° C to 65° C (-30° F to 150° F)

**Humidity:** Standard model: 5% to 95% non-condensing, EWP model: Up to 100%

**Connections:** (5) gel-filled butt connectors (3M Scotchlok UR2)

**Shipping Weight:** 0.55 kg (1.2 lbs)

**Recommended Electrical Box for Flush Mounting:** Single gang with minimum inside dimensions of 2.25" deep x 2.00" wide x 2.84" tall (Carlton BH234R or equivalent)

**Recommended Surface Mount Box:** Viking model **VE-5x5 (DOD# 424)**

**WARNING:** Do **NOT** use a typical "wet location box" as not all styles seal properly with the **E-75** faceplate.

### Proximity Card Reader Specifications

**Power:** 5 to 14V DC @ 60mA maximum

**Maximum Cable Length:** 500 ft 24 Awg stranded shielded (Belden 9537)

**Frequency:** 125KHz

**Format:** 26 bit Wiegand

**Read Range:** 1.25" to 2.0"

**Credential Compatibility:** HID - Proxcard II, ISOProx II and ProxTag II and Pyramid Series Cards and Tags (PSC-1, PSI-4, PSM-2 and PSK-3)

**Transducer:** Beeps during card read

**LED:** Red, turns off during card read

**Humidity:** Up to 100% (fully potted EWP)

**Operating Temperature:** -34° C to 65° C (-30° F to 150° F)

\* **Note:** RG59 or RG6 with solid center conductor and 95% bare copper braid shield.

# Features Overview

**Faceplate:** 18 gauge 304 stainless steel or 16 gauge polished brass faceplate with super durable UV stable powder paint to prevent fading and resist scratching.

**Color Video Camera:** Wide operating temperature range of -30°F to 150°F, NTSC composite video output with 420 lines of resolution, 70° wide viewing angle lens, tilt and swivel adjustments for aiming towards visitors. Impact resistant polycarbonate lens with scratch resistant coating and water-tight gasket.

**Proximity Card Reader:** 26-bit Wiegand, 125KHZ, red LED turns off and transducer will beep during card read. Fully potted EWP. Read range 1.25" to 2.0". Impact resistant polycarbonate lens with water-tight gasket.

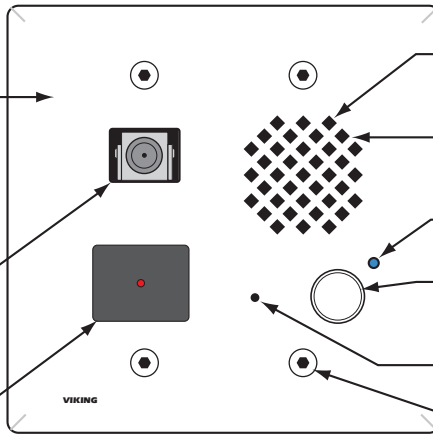

**Speaker Screen:** Stainless steel speaker screen with 0.018" diameter holes to prevent punctures from paperclips, etc.

**Speaker:** Mylar speaker with rubber gasket to maintain water-tight seal and eliminate water deterioration.

**Blue LED:** Helps locate the push button, indicate ringing and off-hook conditions.

**Push Button Switch:** Push to initiate call, push again to disconnect. Solid 304 stainless steel internally sealed per IP67.

**Microphone:** Omni-directional microphone with protective water-resistant cloth.

**Mounting Screws:** 6-32 x 1.25" long flathead with 5/64" hexdrive, 18-8 stainless steel to prevent corrosion.

**Entry Phone Board:** Compact analog speaker phone with call progress detection for automatic disconnect.

**Speaker Volume**

**Microphone Volume**

**Earth Ground:** To increase surge protection, loosen the screw labeled  $\oplus$  (as shown) and fasten a wire with ring terminal (included) from the mounting screw to Earth Ground (grounding rod, water pipe, etc.)

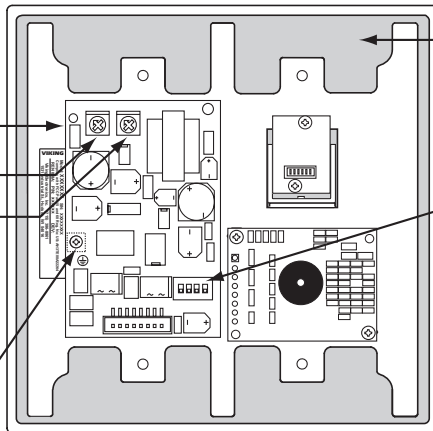

**Faceplate Gasket:** 1/8" thick closed cell PVC to provide a water-tight seal.

**DIP Switches (see page 6):**

- 1: Auto Answer Feature (on/off)
- 2: Dial Tone Detection (on/off)
- 3: Programming Switch (normal/programming)
- 4: LED (on/off)

# Installation

The **E-75** is designed to be flush mounted into a standard double gang rough-in box with minimum inside dimensions of 2.25" deep x 3.65" wide x 2.84" tall. The **E-75** can also be surface mounted in a Viking model **VE-5x5** (not included, see **Fax Back Doc 424**).

**WARNING:** Do **NOT** use a typical "wet location box" as not all styles seal properly with the **E-75** faceplate.

## A. New Construction Flush Mounting

<b>Step 1.</b>	Recommended mounting height to bottom of the rough-in box is 50" - 54". Front of box should stick out approximately 1/2" from front surface of wall stud (this may vary depending on the walls sheathing and siding thickness). <b>Caution:</b> Rough-In box must be mounted <b>LEVEL</b> and must <b>NOT</b> stick out beyond the front surface of siding.
<b>Step 2.</b>	To maintain a vapor barrier on outside wall applications, caulk around the box, filling any gaps between the box and the rough opening. Apply caulk to any holes in the box around wires, etc.
<b>Step 3.</b>	When installing siding cut a hole just large enough for the Rough-In box opening. <b>Caution:</b> Too large of a hole can cause plate misalignment and compromise the gasket seal. <b>Note:</b> A siding mounting block is recommended when mounting to vinyl siding or siding with a 4" or less horizontal lap. Contact siding installer for the correct mounting block.

## B. Old Work / Remodel Flush Mounting (Using a recommended Carlon BH234R Rough-In Box)

<b>Step 1.</b>	Recommended mounting height to bottom of the rough-in box is 50" - 54". Make sure mounting location is free of wall studs, wires, etc.
<b>Step 2.</b>	Place Rough-In box <b>LEVEL</b> against siding. Trace outline of box onto siding. <b>Note:</b> A siding mounting block is recommended when mounting to vinyl siding or siding with a 4" or less horizontal lap. Contact siding installer for the correct mounting block.
<b>Step 3.</b>	Cut a hole through the siding and wall sheathing just large enough for the rough-in box. <b>Caution:</b> Too large of a hole can cause plate misalignment and compromise the gasket seal.
<b>Step 4.</b>	The front surface of the Rough-In box can be mounted flush against wood siding or can be recessed and mounted flush against wall sheathing when mounting on aluminum, steel or vinyl siding.
<b>Step 5.</b>	When mounting to 5/8 inch thick or less wall sheathing the two attached screws with wing brackets can be used to secure the Rough-In box. When mounting to surfaces thicker than 5/8 inch, four standard flat head dry wall screws can be used to secure the Rough-In box through its mounting ears (see page 4 section D).
<b>Step 6.</b>	To maintain a vapor barrier on outside wall applications, caulk around the box, filling any gaps between the box and the rough opening. Apply caulk to any holes in the box around wires, etc.

## C. Surface Mounting

A Viking model **VE-5x5** can be used to surface mount an **E-75** to a wall or post. Recommended mounting height to bottom of **VE-5x5** is 50" - 54". Drill a small wire exit hole in wall. Pull wire through and seal hole around wire with putty or caulking. Route wire into the **VE-5x5** box, securely screw it to wall or post and seal hole in box around wire with putty or caulking. **Note:** Conduit may also be used when surface mounting wire, but should not enter through the top of the **VE-5x5**. When routing wiring from above, a drip loop is required. **WARNING:** Do **NOT** use a typical "wet location box" as not all styles seal properly with the **E-75** faceplate.

## D. Mounting the Faceplate

After the Rough-In box or **VE-5x5** is securely mounted, caulking between the box and rough opening is completed (if required), wires are connected, and camera is tilted and rotated to the desired position (as shown in section **G**). Remove paper liner from face plate gasket and place it on back side of face plate aligning with push button hole. Push the 1-1/4" 6-32 screws through faceplate holes and small holes in gasket, the faceplate gasket should retain the screws. Position the circuit board mounting plate over screws. Align screws with double gang box bosses and tighten face plate until gasket is fully collapsed and the push button is protruding through the clearance hole in the face plate. Included 1/4" thick gasket will provide an adequate seal for most siding surfaces; however for rough surfaces (ie: brick, stucco, etc.) additional caulking may be required.

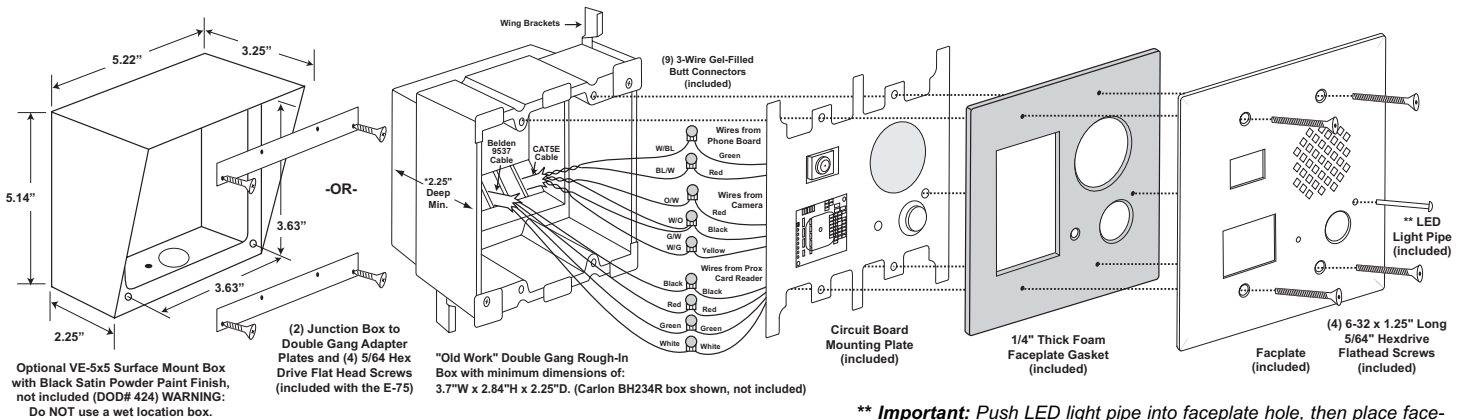

## E. Wiring the E-75 Phone Board

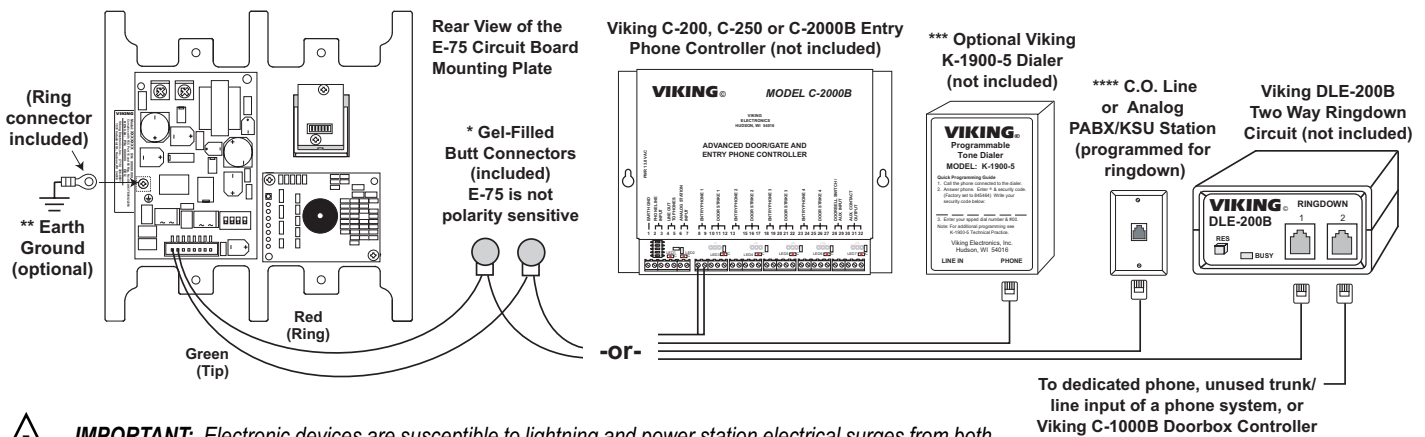

**IMPORTANT:** Electronic devices are susceptible to lightning and power station electrical surges from both the AC outlet and the telephone line. It is recommended that a surge protector be installed to protect against such surges. Contact Panamax at (800) 472-5555 or Electronic Specialists Inc. at (800) 225-4876.

\* **Note:** The gel-filled (water-tight) butt connectors (3M Scotchlok UR2) are designed for insulation displacement on 19-26 gauge wire with a maximum insulation of 0.082 inches. Do not strip wires prior to terminating.

\*\* **Note:** To increase surge protection, loosen the PCB mounting screw labeled  $\oplus$  (as shown above) and fasten a wire with ring terminal (included) from the mounting screw to Earth Ground (grounding rod, water pipe, etc.) After fastening ring terminal to PCB mounting screw, bend terminal up to avoid interference with single gang box.

\*\*\* **Note:** Talk battery must be a minimum of 28V DC when using the speaker phone with a Viking Hot-Line Dialer. For more info, see **DOD# 833**.

\*\*\*\* **Note:** When installing a line powered phone on a low voltage and/or low loop current phone system extension, a Viking **TBB-1B** Talk Battery Booster may be required, see **DOD# 632**.

## F. Wiring the E-75 Camera

### 1. Using RG59 for Video and CAT5 for Camera Power and Phone Board Audio (Recommended)

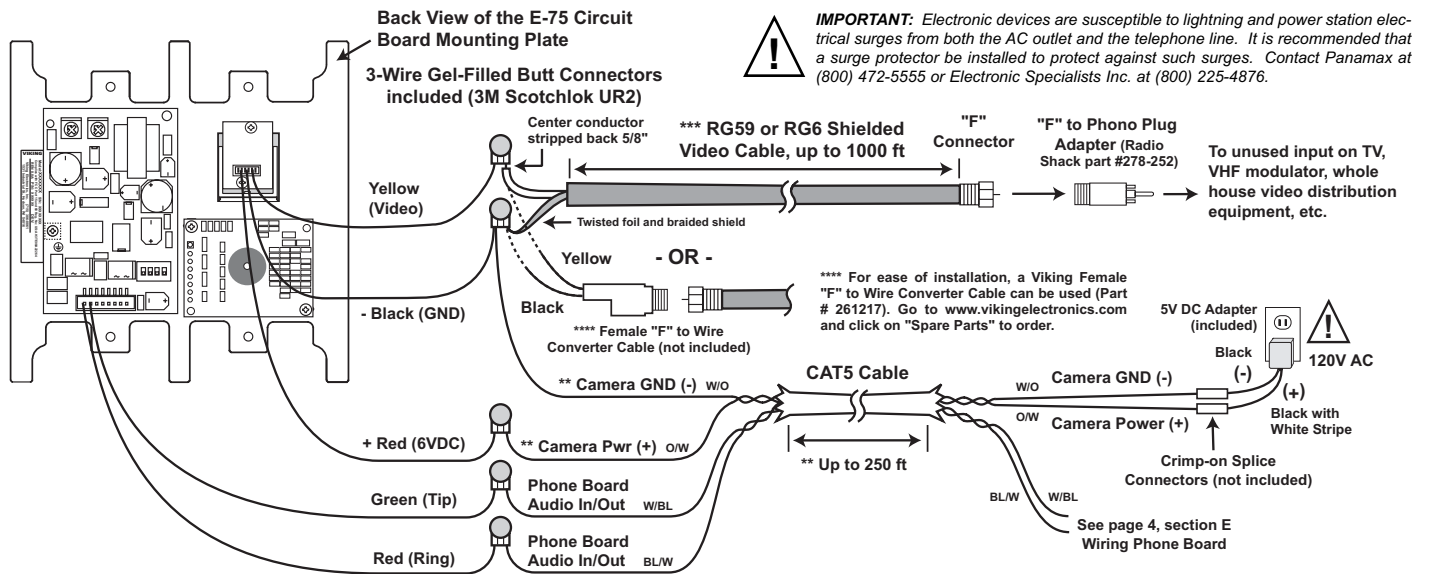

### 2. Using CAT5E or CAT6 for Video, Camera Power and Phone Board Audio (see Caution below)

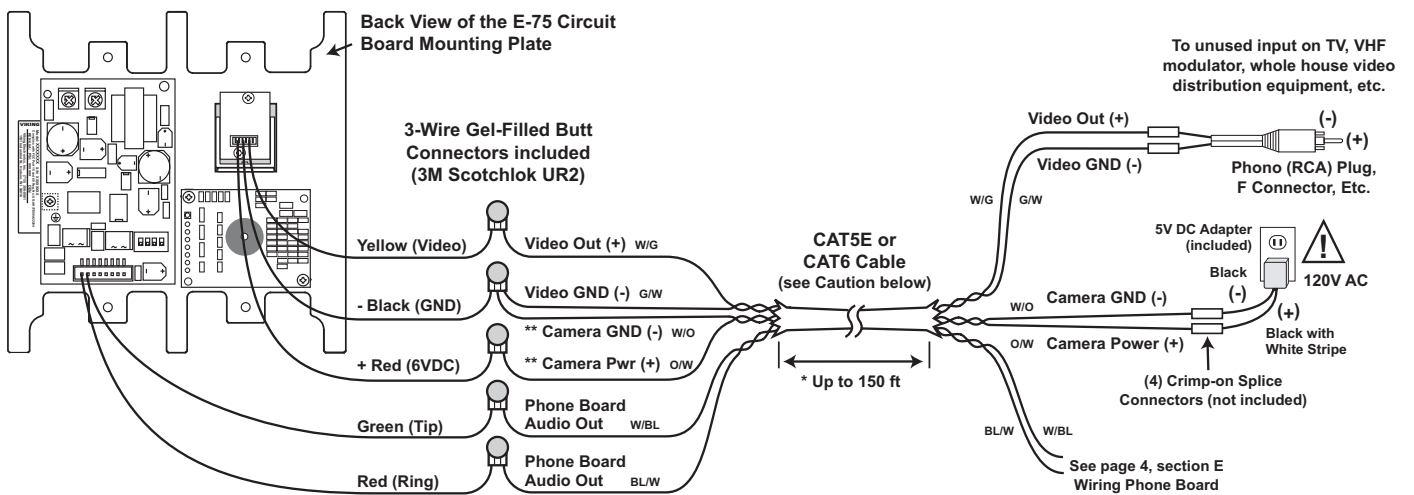

**\* Note:** Up to 150 ft video cable run length can be achieved using CAT5E or CAT6 cable. Longer cable runs can be used if a passive or active video Balun transceiver is used on each end of the cable. Generally, passive transceivers can achieve up to 750 ft cable runs where active transceivers can achieve up to 3000 ft runs depending on cable type, etc. The type of video balun transceiver required is specific to your cable run length. For more information on video balun transceivers go to: [www.northernvideo.com](http://www.northernvideo.com).

**\*\* Note:** The maximum camera power supply wire run length is 250 ft of 24 gauge wire (CAT 5/6), longer runs are possible by doubling pairs, increasing the wire gauge or using a 6V DC 200mA power adapter (Viking part # L122110). Go to [www.vikingelectronics.com](http://www.vikingelectronics.com) and click on "Spare Parts".

**\*\*\* Note:** RG59 or RG6 with solid center conductor and 95% bare copper braid shield.

**Caution:** When routing CAT5E or CAT6 cable, maintain a minimum distance of 3 ft from any parallel high voltage wire (110 VAC) and a minimum of 2 ft from crossing any high voltage wire. For installations where RF noise is expected (commercial applications) or wire runs are near high voltage (110 VAC) wires, a shielded video cable such as RG6 is recommended.

## G. Adjusting the Camera

The camera can be tilted and rotated to your desired position. A portable service (test) monitor can be used to determine the correct viewing angle during installation.

**Important:** To prevent the edge of the faceplate from being viewed in the video image, do not rotate the camera beyond 30 degrees or tilt beyond 20 degrees.

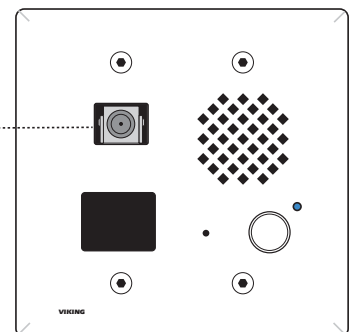
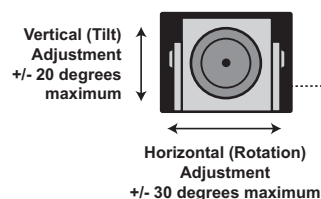

## H. Wiring the Proximity Card Reader

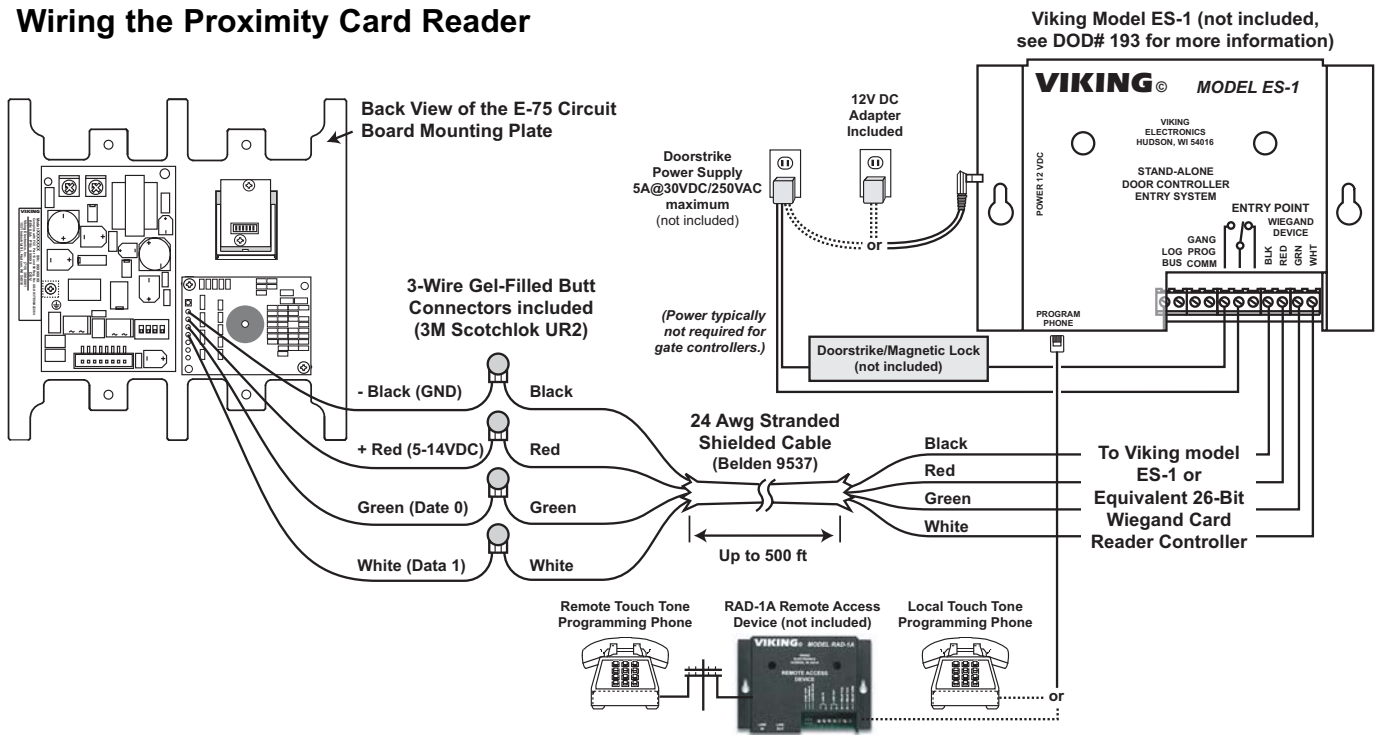

# Programming

### A. Adjusting Speaker Volume

The speaker volume pot can be adjusted to increase or decrease the speaker volume to the level desired.

### B. Adjusting the Microphone Volume

In certain noisy locations (background traffic, machinery or wind), the microphone volume may need to be decreased. A symptom of this is one-way talk path, in which the distant party cannot be heard over the speaker. A microphone volume pot is provided for increasing or decreasing the microphone volume. **Note:** If the microphone volume is set too high or too low, one-way talk path may occur.

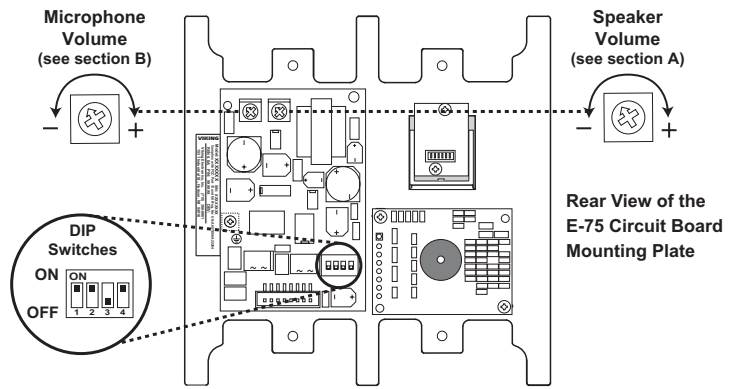

**Note:** Pots and DIP switches are shown in factory default settings.

### C. DIP Switch Programming

#### 1. Auto Answer Feature ON/OFF (DIP Switch 1)

DIP switch 1 is for turning the Auto Answer feature ON and OFF. The E-75 is factory set to auto answer when an inbound call is detected.

#### 2. Dial Tone Detection ON/OFF (DIP Switch 2)

With DIP switch 2 in the ON position, if the E-75 detects more than 5 seconds of continued dial tone, the unit will automatically disconnect. If the E-75 is installed on a continuously noisy line, it may detect the noise as dial tone and automatically disconnect. If this happens, turn the dial tone detection (DIP switch 2) OFF.

#### 3. Programming Mode ON/OFF (DIP Switch 3)

With DIP switch 3 in the OFF position, the E-75 is in the "Normal Operation Mode" (factory setting). By placing DIP switch 3 in the ON position, the E-75's programming mode is enabled. The programming mode is used for adjusting the Call Length Time Out, Silence Time for automatic disconnect and the Talk/Listen delay (VOX switching speed). These features are set from the factory and normally do not need adjustment. If adjustment is necessary, see **Programming** sections **D - I**.

Switch	Position	Description
1	ON	Auto-Answer ON *
1	OFF	Auto-Answer OFF
2	ON	Dial Tone Detection ON *
2	OFF	Dial Tone Detection OFF
3	ON	Programming Mode
3	OFF	Normal Operation Mode *
4	ON	LED On *
4	OFF	LED Off

\* **Note:** These are the factory settings.

#### 4. LED On/Off (DIP Switch 4)

With DIP switch 4 in the ON position, the blue faceplate LED will remain on at all times (to help locate push button switch in dark locations), dim to indicate off hook and flash to indicate incoming ring. When connecting an **E-75** to a C.O.line, turn the LED off to comply with FCC regulations.

### D. Accessing the Programming Mode

The **E-75** can be programmed from any Touch Tone phone using a telephone line, Viking model **C-200**, **C-250** or **C-2000B** Entry Phone Controller, analog PABX/KSU station or a Viking model **DLE-200B** Line Simulator.

<b>Step 1.</b>	Move DIP switch 1 to the <b>ON</b> position (sets unit to answer incoming calls - see section <b>C</b> ).
<b>Step 2.</b>	Move DIP switch 3 to <b>ON</b> (incoming calls automatically enter the programming mode - see section <b>C</b> ).
<b>Step 3.</b>	From a Touch Tone phone call the line attached to the <b>E-75</b> .
<b>Step 4.</b>	When the <b>E-75</b> answers, 2 beeps will be heard and you will automatically enter the programming mode.
<b>Step 5.</b>	When finished programming, enter "0000" to exit programming and move DIP switch 3 back to <b>OFF</b> (see section <b>C</b> ).

### E. Quick Programming Features

	Select Feature	Wait for Beep(s)	Enter Time Value	Wait for 2 Beeps
Call length time out (1-9 minutes) (factory set to 11111 = 5 minutes)	0	beep	111...	beep beep
Silence time out for disconnect (10-90 seconds) (factory set to 1111 = 40 secs)	00	beep	111...	beep beep
Talk/listen delay (VOX switching speed) 0.1 - 0.9 seconds (factory set to 111 = 0.3 secs)	000	beep	111...	beep beep
Forced hang-up command (used to exit programming and hang up the <b>E-75</b> )	0000	3 beeps		

See **Table A** in section **G** 

### F. Programming Beeps

If a valid "Feature" is entered, a single beep will be heard and you will have 20 seconds to enter a "Time" value. If an invalid "Feature" (five or more zeros) or forced hang-up command (four zeros) is entered, 3 beeps will be heard and the **E-75** will hang up. If a valid "Time" is entered 2 beeps will be heard and you will have 20 seconds to enter your next "Feature". If an invalid "Talk/Listen Delay Time" is entered (10 or more ones), 3 beeps will be heard and you will have 20 seconds to enter your next "Feature".

### G. Call Length Time Out

This feature selects the maximum length of time that calls can be connected. Programmable in increments of 1 minute up to a maximum of 9 minutes. To disable the call length time out, program ten ones in the "Time" value location. With the call length disabled, the **E-75** phone must rely on CPC, busy, silence or return dial tone to hang-up. Use the chart at the right. \* **Note:** The factory default is 5 minutes.

**Table A**

Time Value	Call Length Time Out	Silence Time Out	Talk/Listen Delay
1	1 min	10 sec	.1 sec
11	2 min	20 sec	.2 sec
111	3 min	30 sec	.3 sec*
1111	4 min	40 sec*	.4 sec
11111	5 min*	50 sec	.5 sec
111111	6 min	60 sec	.6 sec
1111111	7 min	70 sec	.7 sec
11111111	8 min	80 sec	.8 sec
111111111	9 min	90 sec	.9 sec
10 or more	Disabled	Disabled	Error

### H. Silence Time Out

This feature selects the length of time that calls will remain connected without voice activity. Programmable in increments of 10 seconds up to a maximum of 90 seconds. To disable the silence time out, program ten ones in the "Time" value location. Use the chart at the right. \* **Note:** The factory default is 40 seconds.

### I. Talk/Listen Delay (VOX Switching Speed)

This feature selects switching time between talk and listen modes (VOX switching time). Use the chart above.

\* **Note:** The factory default is .3 seconds.

## Operation

When the push button is pressed, the **E-75** phone goes off-hook, much like a standard speaker phone. In the event that the line is busy, the **E-75** will hang-up. The **E-75** will also automatically hang up on CPC, silence, busy signal, return to dial tone or time out. If programmed to auto-answer (DIP switch 1 **ON**), the **E-75** will also answer any incoming call.

The **E-75** color video camera operates completely independently of the **E-75** phone board. With power supplied to the camera, it will continuously output a video signal.

The **E-75** proximity card reader also operates completely independently of the **E-75** phone board. When connected to a Viking **ES-1** (or equivalent card reader controller) the red LED will light, indicating the card reader is powered. The LED will turn off and the transducer will beep indicating a card scan.

# Applications

## A. Sharing a Single E-75 with an Existing Phone Line

**\* Note:** To increase surge protection, fasten a wire from the screw terminal to Earth Ground (grounding rod, water pipe, etc.)

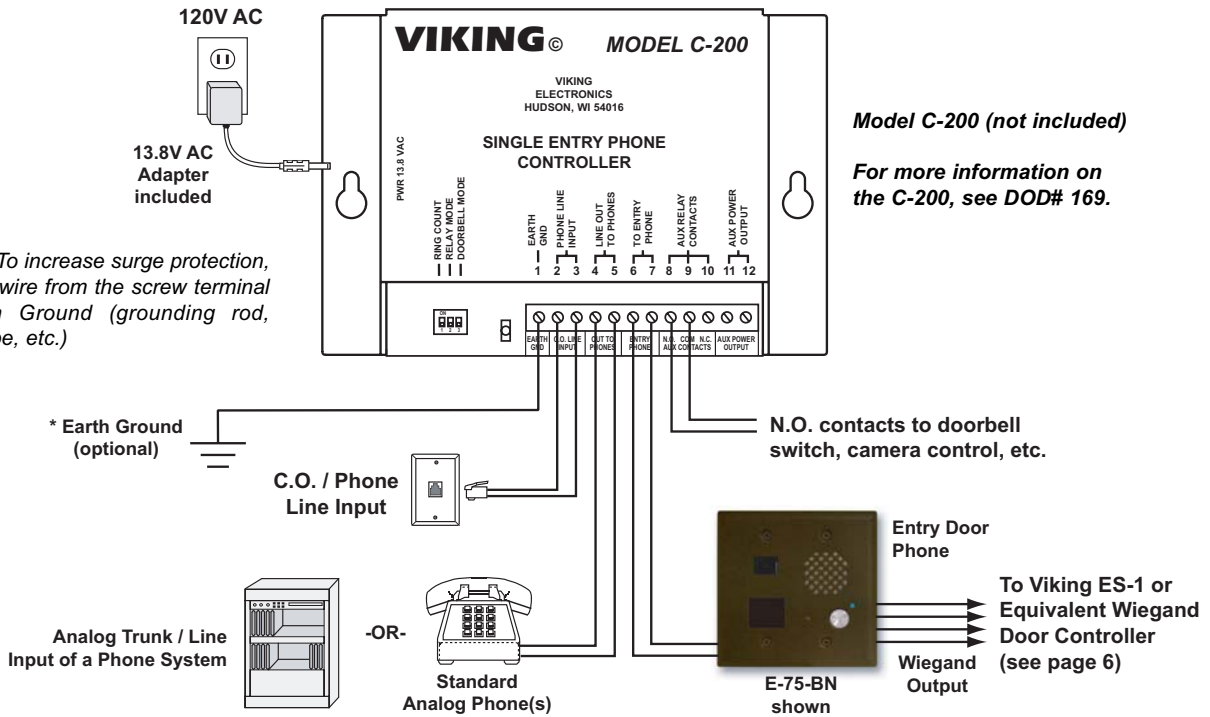

## B. One to Four Entry Phones Sharing a Single Phone Line with Optional Keyless Entry, Doorstrike/Gate Control, and Entry Phone Caller ID

**Model C-2000B (not included)**

**For more information on the C-2000B see DOD# 156.**

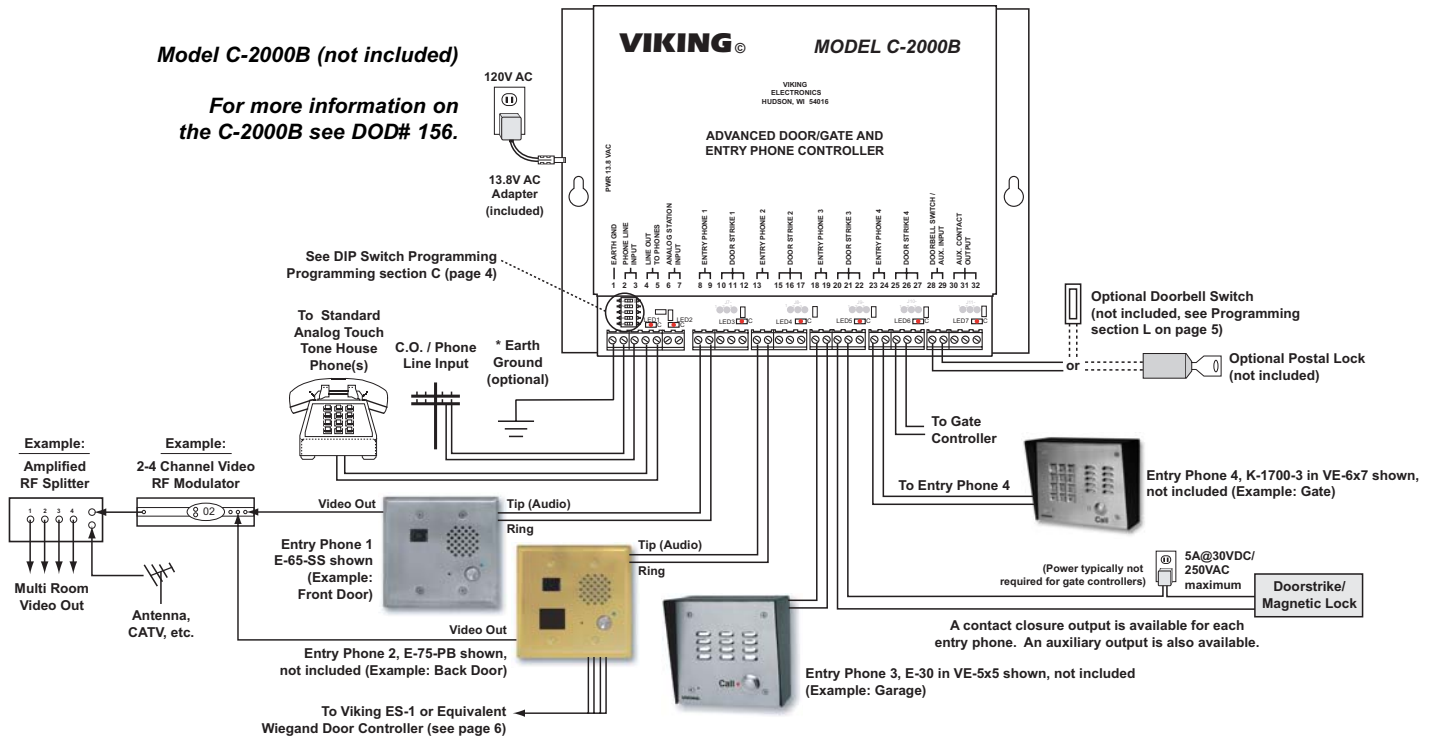

**Product Support Line...715.386.8666**

**Fax Back Line...715.386.4345**

Due to the dynamic nature of the product design, the information contained in this document is subject to change without notice. Viking Electronics, and its affiliates and/or subsidiaries assume no responsibility for errors and omissions contained in this information. Revisions of this document or new editions of it may be issued to incorporate such changes.