

# VIKING

# TECHNICAL Practice

**TELECOM SOLUTIONS FOR THE 21ST CENTURY**

**LDB-3**

**Advanced Ring/  
Loop Detector**

February 21, 2008

## Provide a Contact Closure During Ringing and/or Off-Hook

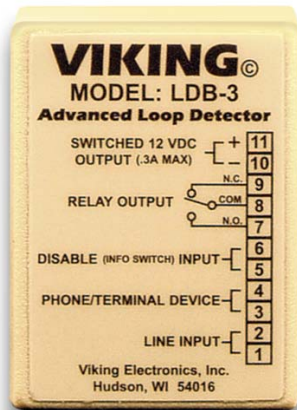

### Ideal for Use with Two-Button Emergency Phones!

The **LDB-3** Advanced Loop Detector monitors an analog phone line for ringing and/or an off hook condition. A built-in relay can be activated when either of these conditions are detected. This is ideal for monitoring line status or for providing a visual indication of such.

The **LDB-3**'s disable input is ideal for two-button emergency phones, such as Viking's **E-1600-20A**, allowing "Info" button calls to be placed without activating the relay (turning on the emergency strobe light, camera, etc.)

Three DIP switches are provided for turning ring detection on or off, off-hook/loop detection on or off and for selecting a ring cadence

mode which allows the relay to follow ringing or to remain activated during the off time of standard ring cadence.

The **LDB-3** comes complete with a 12 VDC power adapter, and can also provide switched 12VDC .35 Amp output to power external lights, etc. during ringing and/or off-hook conditions.

## Features

- Detects ring voltage and off hook loop current
- On/off switches for ring detection and off-hook/loop detection
- Screw terminal connections
- Selectable ring cadence mode (relay can remain on between rings)
- Wall mountable with foam tape (included) or screws (not included)
- Switched 12V DC output (follows relay activation for powering strobe lights, cameras, etc.)
- One set of (NO) normally open or (NC) normally closed relay contacts provided
- Disable input, ideal for use with two-button emergency phones (**E-1600-20A**), will not activate relay on "Info" calls

 Need More Information on the E-1600-20A? Call (715) 386-4345 and select 215.

## Applications

- Control a strobe or beacon light for ring indication
- Provide relay closures on off-hook
- Trigger a security camera
- Trigger a tape recorder
- Phone "In Use" indicator

**Phone... 715.386.8861**

<http://www.vikingelectronics.com>

## Specifications

**Power:** 120V AC to 12V DC adapter provided  
**Dimensions:** 74mm x 53mm x 25mm (2.9" x 2.1" x 1.0")  
**Shipping Weight:** 0.4 kg (0.86 lbs)  
**Environmental:** -26° C to 54° C (-15° F to 130° F) with 5% to 95% non-condensing humidity  
**Relay Contact Rating:** .5A @ 125V AC/1A @ 30V DC  
**Maximum Current Draw Auxiliary 12V DC Output:** 350mA  
**Minimum Loop Current:** 15 mA  
**Disable/Info Switch Input:** 50mA/80mW maximum  
**Ringer Equivalence:** 0.5 A REN  
**Connections:** 2 position and 11 position screw terminal blocks

## IF YOU HAVE A PROBLEM WITH A VIKING PRODUCT, PLEASE CONTACT: VIKING TECHNICAL SUPPORT AT (715) 386-8666

Our Technical Support Department is available for assistance Monday 8am - 4pm and Tuesday through Friday 8am - 5pm central time. So that we can give you better service, before you call please:

1. Know the model number, the serial number and what software version you have (see serial label).
2. Have your Technical Practice in front of you.
3. It is best if you are on site.

### RETURNING PRODUCT FOR REPAIR

The following procedure is for equipment that needs repair:

1. Customer must contact Viking's Technical Support Department at 715-386-8666 to obtain a Return Authorization (RA) number. The customer MUST have a complete description of the problem, with all pertinent information regarding the defect, such as options set, conditions, symptoms, methods to duplicate problem, frequency of failure, etc.
2. Packing: Return equipment in original box or in proper packing so that damage will not occur while in transit. Static sensitive equipment such as a circuit board should be in an anti-static bag, sandwiched between foam and individually boxed. All equipment should be wrapped to avoid packing material lodging in or sticking to the equipment. Include ALL parts of the equipment. C.O.D. or freight collect shipments cannot be accepted. Ship cartons prepaid to: **Viking Electronics, 1531 Industrial Street, Hudson, WI 54016**
3. Return shipping address: Be sure to include your return shipping address inside the box. We cannot ship to a PO Box.
4. RA number on carton: In large printing, write the R.A. number on the outside of each carton being returned.

### RETURNING PRODUCT FOR EXCHANGE

The following procedure is for equipment that has failed out-of-box (within 10 days of purchase):

1. Customer must contact Viking's Technical Support at 715-386-8666 to determine possible causes for the problem. The customer MUST be able to step through recommended tests for diagnosis.
2. If the Technical Support Product Specialist determines that the equipment is defective based on the customer's input and troubleshooting, a Return Authorization (R.A.) number will be issued. This number is valid for fourteen (14) calendar days from the date of issue.
3. After obtaining the R.A. number, return the approved equipment to your distributor, referencing the R.A. number. Your distributor will then replace the product over the counter at no charge. The distributor will then return the product to Viking using the same R.A. number.
4. **The distributor will NOT exchange this product without first obtaining the R.A. number from you. If you haven't followed the steps listed in 1, 2 and 3, be aware that you will have to pay a restocking charge.**

### LIMITED WARRANTY

Viking warrants its products to be free from defects in the workmanship or materials, under normal use and service, for a period of one year from the date of purchase from any authorized Viking distributor or 18 months from the date manufactured, whichever ever is greater. If at any time during the warranty period, the product is deemed defective or malfunctions, return the product to Viking Electronics, Inc., 1531 Industrial Street, Hudson, WI., 54016. Customer must contact Viking's Technical Support Department at 715-386-8666 to obtain a Return Authorization (R.A.) number.

This warranty does not cover any damage to the product due to lightning, over voltage, under voltage, accident, misuse, abuse, negligence or any damage caused by use of the product by the purchaser or others.

**NO OTHER WARRANTIES. VIKING MAKES NO WARRANTIES RELATING TO ITS PRODUCTS OTHER THAN AS DESCRIBED ABOVE AND DISCLAIMS ANY EXPRESS OR IMPLIED WARRANTIES OR MERCHANTABILITY OR FITNESS FOR ANY PARTICULAR PURPOSE.**

**EXCLUSION OF CONSEQUENTIAL DAMAGES. VIKING SHALL NOT, UNDER ANY CIRCUMSTANCES, BE LIABLE TO PURCHASER, OR ANY OTHER PARTY, FOR CONSEQUENTIAL, INCIDENTAL, SPECIAL OR EXEMPLARY DAMAGES ARISING OUT OF OR RELATED TO THE SALE OR USE OF THE PRODUCT SOLD HEREUNDER.**

**EXCLUSIVE REMEDY AND LIMITATION OF LIABILITY. WHETHER IN AN ACTION BASED ON CONTRACT, TORT (INCLUDING NEGLIGENCE OR STRICT LIABILITY) OR ANY OTHER LEGAL THEORY, ANY LIABILITY OF VIKING SHALL BE LIMITED TO REPAIR OR REPLACEMENT OF THE PRODUCT, OR AT VIKING'S OPTION, REFUND OF THE PURCHASE PRICE AS THE EXCLUSIVE REMEDY AND ANY LIABILITY OF VIKING SHALL BE SO LIMITED.**

**IT IS EXPRESSLY UNDERSTOOD AND AGREED THAT EACH AND EVERY PROVISION OF THIS AGREEMENT WHICH PROVIDES FOR DISCLAIMER OF WARRANTIES, EXCLUSION OF CONSEQUENTIAL DAMAGES, AND EXCLUSIVE REMEDY AND LIMITATION OF LIABILITY, ARE SEVERABLE FROM ANY OTHER PROVISION AND EACH PROVISION IS A SEPARABLE AND INDEPENDENT ELEMENT OF RISK ALLOCATION AND IS INTENDED TO BE ENFORCED AS SUCH.**

### FCC REQUIREMENTS

This equipment complies with Part 68 of the FCC rules and the requirements adopted by the ACTA. On the side of this equipment is a label that contains, among other information, a product identifier in the format US:AAAEQ##TXXXX. If requested, this number must be provided to the telephone company.

The REN is used to determine the number of devices that may be connected to a telephone line. Excessive REN's on a telephone line may result in the devices not ringing in response to an incoming call. In most but not all areas, the sum of the REN's should not exceed five (5.0) To be certain of the number of devices that may be connected to a line, as determined by the total REN's, contact the local telephone company. For products approved after July 23, 2001, the REN for this product is part of the product identifier that has the format US:AAAEQ##TXXXX. The digits represented by ## are the REN without a decimal point (e.g., 03 is a REN of 0.3). For earlier products, the REN is separately shown on the label.

The plug used to connect this equipment to the premises wiring and telephone network must comply with the applicable FCC Part 68 rules and requirements adopted by the ACTA. If your home has specially wired alarm equipment connected to the telephone line, ensure the installation of this LDB-3 does not disable your alarm equipment. If you have questions about what will disable alarm equipment, consult your telephone company or a qualified installer.

If the LDB-3 causes harm to the telephone network, the telephone company will notify you in advance that temporary discontinuance of service may be required. But if advance notice isn't practical, the telephone company will notify the customer as soon as possible. Also, you will be advised of your right to file a complaint with the FCC if you believe it is necessary.

The telephone company may make changes in its facilities, equipment, operations, or procedures that could affect the operation of the equipment. If this happens, the telephone company will provide advance notice in order for you to make

the necessary modifications to maintain uninterrupted service.

If trouble is experienced with the LDB-3, for repair or warranty information, please contact:

**Viking Electronics, Inc., 1531 Industrial Street, Hudson, WI 54016 (715) 386-8666**

If the equipment is causing harm to the telephone network, the telephone company may request that you disconnect the equipment until the problem is resolved.

Connection to Party Line Service is subject to State Tariffs. Contact the state public utility commission, public service commission or corporation commission for information.

#### WHEN PROGRAMMING EMERGENCY NUMBERS AND (OR) MAKING TEST CALLS TO EMERGENCY NUMBERS:

Remain on the line and briefly explain to the dispatcher the reason for the call. Perform such activities in the off-peak hours, such as early morning or late evenings.

It is recommended that the customer install an AC surge arrester in the AC outlet to which this device is connected. This is to avoid damaging the equipment caused by local lightning strikes and other electrical surges.

### PART 15 LIMITATIONS

This equipment has been tested and found to comply with the limits for a Class A digital device, pursuant to Part 15 of the FCC Rules. These limits are designed to provide reasonable protection against harmful interference when the equipment is operated in a commercial environment. This equipment generates, uses, and can radiate radio frequency energy and, if not installed and used in accordance with the instruction manual, may cause harmful interference to radio communications. Operation of this equipment in a residential area is likely to cause harmful interference in which case the user will be required to correct the interference at his own expense.

# Installation

## A. Using Screws (not included)

<b>Step 1.</b>	Unsnap the plastic cover and remove the top screw holding the circuit board.
<b>Step 2.</b>	Loosen the bottom screw and rotate the circuit board to the left, exposing the two mounting holes in the base.
<b>Step 3.</b>	Screw the base to the wall, etc. using (2) #6 flathead or sheetrock screws. <b>Note:</b> Make sure the screw heads are fully driven into the base to avoid shorting the circuit board leads.

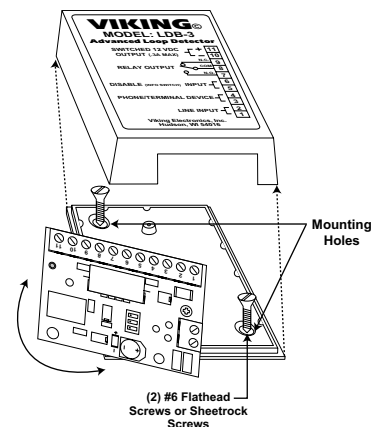

## B. Using the Included Tape

<b>Step 1.</b>	Clean the back of the LDB-3 and the surface you are mounting to with rubbing alcohol before mounting.
<b>Step 2.</b>	Remove the backing on one side of the tape and adhere to the LDB-3. Remove the rest of the backing and press unit firmly to surface you are mounting to.

## C. Preparing the Power Supply

<b>Step 1.</b>	Cut off the barrel connector on the power supply (see right).
<b>Step 2.</b>	Separate and strip wires (see right).
<b>Step 3.</b>	Connect to the screw terminal block on the LDB-3, then plug in power supply (see right).

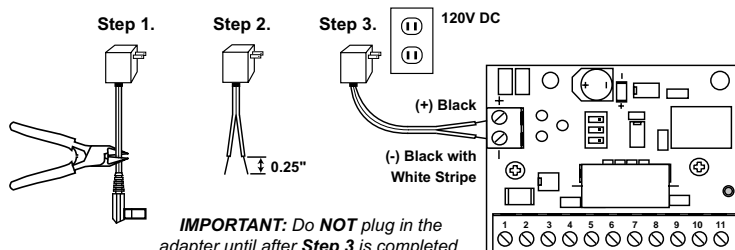

# Programming

## A. DIP Switches

Sw 1	Sw 3	Description
ON	OFF	Ring Detection Only (see section B)
OFF	ON	Off-Hook/Loop Current Detection Only (see section C)
ON	ON	Ring and Off-Hook/Loop Current Detection (see section D)

Sw 2	Ring Cadence Mode (see section E)
ON	Ring Cadence Mode ON - relay remains activated in between rings.
OFF	Ring Cadence Mode OFF - relay is activated only during ringing.

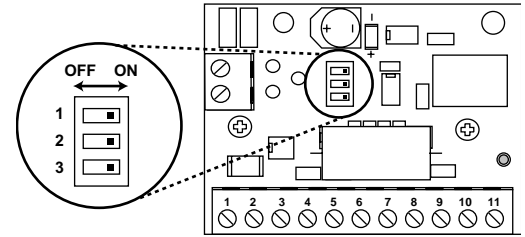

## B. Ring Detection Only

Connect the incoming line to terminal block positions **1** and **2** as shown in the diagram. No terminal device (phone) is required. In this manner, the **LDB-3** can monitor for ringing any place along the ringing line.

## C. Off-Hook/Loop Current Detection Only

The **LDB-3** must be placed between the phone line and the terminal device (phone) to be monitored. Connect the incoming line to positions **1** and **2** and connect the terminal device (phone) to positions **3** and **4**.

## D. Ring and Off-Hook/Loop Current Detection

If the application requires off-hook (loop) and ring detection, the **LDB-3** must be placed between the phone line and the terminal device (phone) to be monitored. Connect the incoming line to positions **1** and **2**, connect the terminal device (phone) to positions **3** and **4**.

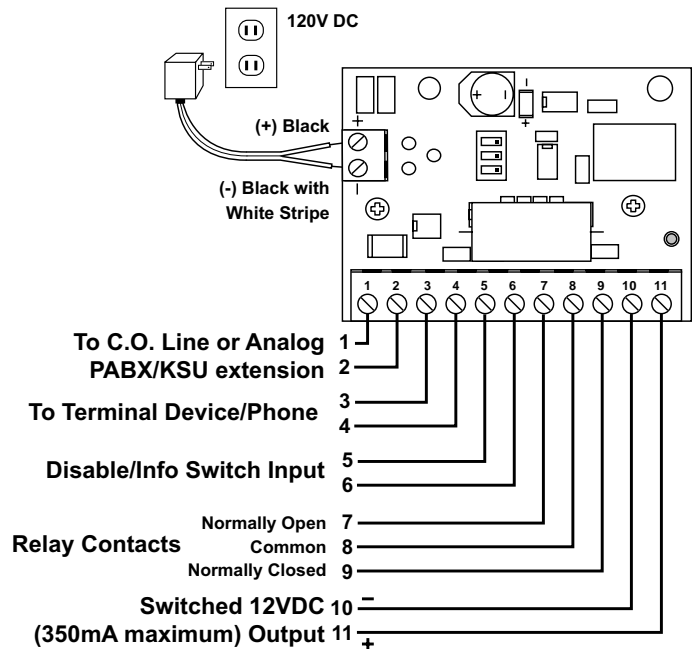

## E. Ring Cadence Mode

DIP switch **2** is used for switching between different ring detection modes. In the **OFF** position, the relay and switched 12VDC output will activate only while ring voltage is present and will turn off between rings. In the **ON** position, the relay and switched 12VDC output will remain on for up to 5.75 seconds after the ringing has stopped. This allows the relay and 12VDC to remain on between rings of a standard ring cadence. **Note:** To use the Ring Cadence Mode, ring detection **MUST** be enabled (DIP switch **1** - **ON**).

## F. Relay Contacts

Normally open and normally closed relay contacts are available at terminal block positions **7**, **8**, **9**. The contacts are rated at **.5A @ 125VAC/1A @ 30VDC**. If contacts are driving an inductive load, place a suppression device at the load to snub high voltage spikes.

## G. Switched 12V DC Output

The switched 12V DC output is a low current, 12-15VDC output that is turned on only while the ring/loop detect relay is activated. This switched power output is ideal for lighting strobe lights or powering up any device that draws less than 350mAmps. The positive side is available at terminal position **11**, and the negative side is at position **10**. Once all the line and load connections have been made, plug in the 115 V AC wall adapter, and replace the cover.

## H. Disable Feature

By connecting the Disable/Info Switch input of the **LDB-3** to the "Info" switch of Viking's **E-1600-20A**, **E-1600-20A-EWP**, **E-1600-52A** or **E-1600-52A-EWP** Emergency Phone (not included), any outbound calls initiated from the "Info" button will not activate the loop detect relay. This way, only the "Help/Emergency" outbound calls will activate the relay. Cut one of the "Info" switch wires in half and connect each end to **LDB-3** terminals 5 and 6 as shown in the diagram at the right.

**Note:** The Disable input is **NOT** polarity sensitive.

The "Disable" input can be connected to a remote switch, contact closure, etc. for deactivating the **LDB-3**'s internal relay.

This can be useful to turn off the controlled device (strobe light, camera, etc.) Use the diagram shown at the right.

If the relay has been activated by ringing, the switch will deactivate the relay and ringing must stop for a minimum of 6 seconds before the relay can be reactivated from a new incoming call.

Rear View of E-1600-20A

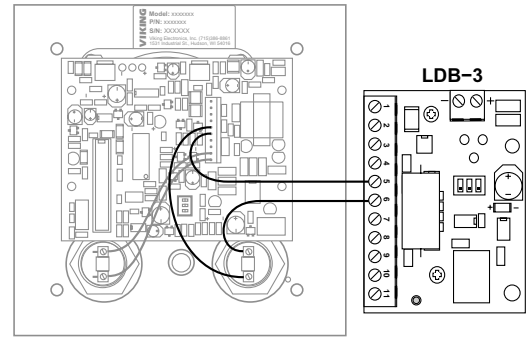

Momentary Switch

390 Ohm - 750 Ohm, 1/2 Watt Resistor  
(Radio Shack part # 271-1114, 271-1115,  
271-1116, 271-1117 or equivalent)

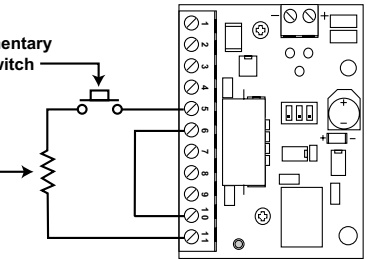

## Other Products

### BLK-3-EWP Strobe Light Kit

The **BLK-3-EWP** can be used to add emergency notification to pre-installed emergency phones. The **BLK-3-EWP** is equipped with Enhanced Weather Protection (EWP) and will not flash on "Info" calls when used with the **E-1600-20A** or **E-1600-52A**. Alternatively, the **BLK-3-EWP** provides high visibility indication of analog line status through a high powered strobe light. The **BLK-3-EWP** is an ideal solution for the hearing impaired and can be used equally well in loud warehouses or factories, where ringing phones can not be heard.

 Need More Information on the BLK-3-EWP?  
Call (715) 386-4345 and select 653.



### ADA Compliant Emergency Phones



The **1600A Series** ADA Compliant Emergency Phones are designed to provide quick and reliable handsfree communication for any standard analog telephone line or analog phone system station port. All **1600A Series** phones meet ADA requirements for elevator/ emergency telephones, and can be programmed from any Touch Tone phone. The phones can dial up to 5 programmable emergency numbers, as well as 2 central station numbers. In addition, the **E-1600-20A** and **E-1600-52A** feature a second "INFO" button that will dial up to 3 non-emergency numbers.

The **1600A Series** phones can be programmed to automatically deliver a digital announcement to identify the location of the emergency call. Alternatively, a DTMF Touch Tone code may also be delivered. A "Call Connected" LED can be initiated manually or automati-

cally. All programming parameters, including phone numbers and location numbers, are stored in non-volatile memory. All units are phone line powered, requiring no batteries or external power and are compatible with common Central Station Monitoring equipment.

For outdoor or harsh environments, select **1600A Series** phones are available with Enhanced Weather Protection (**EWP**). EWP products feature rubber gaskets and boots, hand soldered silicon sealed connections, gel-filled butt connectors, as well as urethane potted circuit boards with weather sealed, field-adjustable trim pots and DIP switches for easy on-site programming.

Product Support Line...715.386.8666

Fax Back Line...715.386.4345

Due to the dynamic nature of the product design, the information contained in this document is subject to change without notice. Viking Electronics, and its affiliates and/or subsidiaries assume no responsibility for errors and omissions contained in this information. Revisions of this document or new editions of it may be issued to incorporate such changes.