

VIKING

TECHNICAL Practice

TELECOM SOLUTIONS FOR THE 21ST CENTURY

DNA-510

Digital Mass
Notification Announcer

March 11, 2010

Add Emergency Mass Notification Messages and Alert Tones to your Existing Paging System



The **DNA-510** is a digital mass notification announcer, capable of providing up to 2 minutes of digitally recorded voice emergency instructions and alert tones over your existing paging system.

The **DNA-510** connects to a phone line, analog phone system station or a phone system's unused trunk/line input allowing you to securely page, trigger emergency messages and/or alert tones and program the unit from any remote touch tone phone.

When activated, the **DNA-510** will interrupt any current paging or background music and inject an emergency voice message and/or alert tone over your paging system. A live page can also be announced.

The **DNA-510** can be programmed to repeat one up to 2 minute message, two up to 1 minute messages, three up to 40 second messages, four up to 30 second messages or five up to 24 second messages. It can also be programmed with 10 different alert tones for emergency mass notification of: evacuation, lock down, severe weather, fire, bomb threat, hazardous material release, tornado, flash flood, terrorist alert, all-clear, etc.

Features

- Non-volatile memory - retains programming during power outage
 - Up to 2 minutes of total message record time
 - Record up to 5 different emergency messages
 - Ten different emergency alert tones:
 1. Hi/Low Siren
 2. Code 3 Temporal (ANSI S3.41) Slow Whoop
 3. Attack Wail*
 4. Alert Siren*
 5. Fast Wail*
 6. Fast Whoop
 7. March Time Horn
 8. Bell*
 9. Buzzer
 10. All Clear Tone
- *Note: Looping recordings of actual emergency sirens and alarm bell.*
- Call progress detection for automatic hang up on CPC, busy signal, dial tone or 20 seconds of silence (During live page only).
 - Separate volume controls for paging, messages and alert tones
 - Automatically interrupts current page or background music to inject emergency announcement, alert tones or live page
 - Programmable trigger input to activate a message and/or alert tone
 - N.O. & N.C. trigger output contacts for activating flashing beacon (**BLK-3-EWP**), Alarm Dialer (**K-202-DVA**), etc.
 - Access code to prevent fraudulent use
 - Connects directly to an unused line input (trunk) or station port of a phone system or to a dedicated phone line

Applications

Provide Emergency Mass Notification for:

- Schools
- College Campuses
- Restaurants
- Churches
- Theaters
- Auditoriums
- Dormitories
- Office buildings
- Factories
- Any "areas of assembly"

Phone...715.386.8861

Specifications

Power: 120V AC/13.8V AC 1.25A UL listed adapter provided
Dimensions: 133 mm x 91 mm x 44 mm (5.25" x 3.58" x 1.75")
Weight: 0.8 kg (1.76 lbs)
Environmental: 0°C to 32°C (32°F to 90°F) with 5% to 95% non-condensing humidity
Sampling Rate: 96K (equivalent)
Connections: (2) RCA audio jacks, 11 position cage clamp terminal strip
Audio output: 600 ohm with volume adjustable potentiometer, maximum level = 2.2 dBm/ 1V RMS across 600 ohm load
Page Trigger Output: 12V DC (20mA maximum) or N.O./N.C. relay contacts (1A 30V DC / 0.3A 110V AC maximum)

IF YOU HAVE A PROBLEM WITH A VIKING PRODUCT, PLEASE CONTACT: VIKING TECHNICAL SUPPORT AT (715) 386-8666

Our Technical Support Department is available for assistance Monday 8am - 4pm and Tuesday through Friday 8am - 5pm central time. So that we can give you better service, before you call please:

1. Know the model number, the serial number and what software version you have (see serial label).
2. Have your Technical Practice in front of you.
3. It is best if you are on site.

RETURNING PRODUCT FOR REPAIR

The following procedure is for equipment that needs repair:

1. Customer must contact Viking's Technical Support Department at 715-386-8666 to obtain a Return Authorization (RA) number. The customer MUST have a complete description of the problem, with all pertinent information regarding the defect, such as options set, conditions, symptoms, methods to duplicate problem, frequency of failure, etc.
2. Packing: Return equipment in original box or in proper packing so that damage will not occur while in transit. Static sensitive equipment such as a circuit board should be in an anti-static bag, sandwiched between foam and individually boxed. All equipment should be wrapped to avoid packing material lodging in or sticking to the equipment. Include ALL parts of the equipment. C.O.D. or freight collect shipments cannot be accepted. Ship cartons prepaid to:
Viking Electronics, 1531 Industrial Street, Hudson, WI 54016
3. Return shipping address: Be sure to include your return shipping address inside the box. We cannot ship to a PO Box.
4. RA number on carton: In large printing, write the R.A. number on the outside of each carton being returned.

RETURNING PRODUCT FOR EXCHANGE

The following procedure is for equipment that has failed out-of-box (within 10 days of purchase):

1. Customer must contact Viking's Technical Support at 715-386-8666 to determine possible causes for the problem. The customer MUST be able to step through recommended tests for diagnosis.
2. If the Technical Support Product Specialist determines that the equipment is defective based on the customer's input and troubleshooting, a Return Authorization (R.A.) number will be issued. This number is valid for fourteen (14) calendar days from the date of issue.
3. After obtaining the R.A. number, return the approved equipment to your distributor, referencing the R.A. number. Your distributor will then replace the product over the counter at no charge. The distributor will then return the product to Viking using the same R.A. number.
4. **The distributor will NOT exchange this product without first obtaining the R.A. number from you. If you haven't followed the steps listed in 1, 2 and 3, be aware that you will have to pay a restocking charge.**

LIMITED WARRANTY

Viking warrants its products to be free from defects in the workmanship or materials, under normal use and service, for a period of one year from the date of purchase from any authorized Viking distributor or 18 months from the date manufactured, which ever is greater. If at any time during the warranty period, the product is deemed defective or malfunctions, return the product to Viking Electronics, Inc., 1531 Industrial Street, Hudson, WI., 54016. Customer must contact Viking's Technical Support Department at 715-386-8666 to obtain a Return Authorization (R.A.) number.

This warranty does not cover any damage to the product due to lightning, over voltage, under voltage, accident, misuse, abuse, negligence or any damage caused by use of the product by the purchaser or others.

NO OTHER WARRANTIES. VIKING MAKES NO WARRANTIES RELATING TO ITS PRODUCTS OTHER THAN AS DESCRIBED ABOVE AND DISCLAIMS ANY EXPRESS OR IMPLIED WARRANTIES OR MERCHANTABILITY OR FITNESS FOR ANY PARTICULAR PURPOSE.

EXCLUSION OF CONSEQUENTIAL DAMAGES. VIKING SHALL NOT, UNDER ANY CIRCUMSTANCES, BE LIABLE TO PURCHASER, OR ANY OTHER PARTY, FOR CONSEQUENTIAL, INCIDENTAL, SPECIAL OR EXEMPLARY DAMAGES ARISING OUT OF OR RELATED TO THE SALE OR USE OF THE PRODUCT SOLD HEREUNDER.

EXCLUSIVE REMEDY AND LIMITATION OF LIABILITY. WHETHER IN AN ACTION BASED ON CONTRACT, TORT (INCLUDING NEGLIGENCE OR STRICT LIABILITY) OR ANY OTHER LEGAL THEORY, ANY LIABILITY OF VIKING SHALL BE LIMITED TO REPAIR OR REPLACEMENT OF THE PRODUCT, OR AT VIKING'S OPTION, REFUND OF THE PURCHASE PRICE AS THE EXCLUSIVE REMEDY AND ANY LIABILITY OF VIKING SHALL BE SO LIMITED.

IT IS EXPRESSLY UNDERSTOOD AND AGREED THAT EACH AND EVERY PROVISION OF THIS AGREEMENT WHICH PROVIDES FOR DISCLAIMER OF WARRANTIES, EXCLUSION OF CONSEQUENTIAL DAMAGES, AND EXCLUSIVE REMEDY AND LIMITATION OF LIABILITY, ARE SEVERABLE FROM ANY OTHER PROVISION AND EACH PROVISION IS A SEPARABLE AND INDEPENDENT ELEMENT OF RISK ALLOCATION AND IS INTENDED TO BE ENFORCED AS SUCH.

FCC REQUIREMENTS

This equipment complies with Part 68 of the FCC rules and the requirements adopted by the ACTA. On the side of this equipment is a label that contains, among other information, a product identifier in the format US:AAAEQ##TXXXX. If requested, this number must be provided to the telephone company.

The REN is used to determine the number of devices that may be connected to a telephone line. Excessive REN's on a telephone line may result in the devices not ringing in response to an incoming call. In most but not all areas, the sum of the REN's should not exceed five (5.0) To be certain of the number of devices that may be connected to a line, as determined by the total REN's, contact the local telephone company. For products approved after July 23, 2001, the REN for this product is part of the product identifier that has the format US:AAAEQ##TXXXX. The digits represented by ## are the REN without a decimal point (e.g., 03 is a REN of 0.3). For earlier products, the REN is separately shown on the label.

The plug used to connect this equipment to the premises wiring and telephone network must comply with the applicable FCC Part 68 rules and requirements adopted by the ACTA. If your home has specially wired alarm equipment connected to the telephone line, ensure the installation of this DNA-510 does not disable your alarm equipment. If you have questions about what will disable alarm equipment, consult your telephone company or a qualified installer.

If the DNA-510 causes harm to the telephone network, the telephone company will notify you in advance that temporary discontinuance of service may be required. But if advance notice isn't practical, the telephone company will notify the customer as soon as possible. Also, you will be advised of your right to file a complaint with the FCC if you believe it is necessary.

The telephone company may make changes in its facilities, equipment, operations, or procedures that could affect the operation of the equipment. If this happens, the telephone company will provide advance notice in order for you to make

the necessary modifications to maintain uninterrupted service.

If trouble is experienced with the DNA-510, for repair or warranty information, please contact:

Viking Electronics, Inc., 1531 Industrial Street, Hudson, WI 54016 (715) 386-8666

If the equipment is causing harm to the telephone network, the telephone company may request that you disconnect the equipment until the problem is resolved.

Connection to Party Line Service is subject to State Tariffs. Contact the state public utility commission, public service commission or corporation commission for information.

WHEN PROGRAMMING EMERGENCY NUMBERS AND (OR) MAKING TEST CALLS TO EMERGENCY NUMBERS:

Remain on the line and briefly explain to the dispatcher the reason for the call. Perform such activities in the off-peak hours, such as early morning or late evenings.

It is recommended that the customer install an AC surge arrester in the AC outlet to which this device is connected. This is to avoid damaging the equipment caused by local lightning strikes and other electrical surges.

PART 15 LIMITATIONS

This equipment has been tested and found to comply with the limits for a Class A digital device, pursuant to Part 15 of the FCC Rules. These limits are designed to provide reasonable protection against harmful interference when the equipment is operated in a commercial environment. This equipment generates, uses, and can radiate radio frequency energy and, if not installed and used in accordance with the instruction manual, may cause harmful interference to radio communications. Operation of this equipment in a residential area is likely to cause harmful interference in which case the user will be required to correct the interference at his own expense.

Features Overview

Paging Volume Control - To adjust audio output level of "live" paging. *Note: This does not control the paging volume from your phone system's paging port.*

Power Input - Connect to provided 13.8V AC 1.25A adapter.

Audio Loop Input - Line level pre-amp input for non-emergency paging, background music etc. (RCA type connector)

Audio Loop Output 1 - Line level output to paging amplifier (RCA type connector, also available on screw terminals 2 & 3 "Audio Out 2".

Alert Tone Volume Control - To adjust audio output level of synthesized alert tones (hi/low, code 3 whoop, fast whoop, march time horn, buzzer, all clear)

1 & 2: Optional Message Record Input - Connect to output of tape player, PC sound card, etc. to record professional messages or unique alert tones. *Note: This is optional, normal recording is done via telephone.*

2 & 3: Audio Loop Out 2 - Same as Audio Loop Out 1 but uses screw terminal connections. See Audio Loop Out 1 (above).

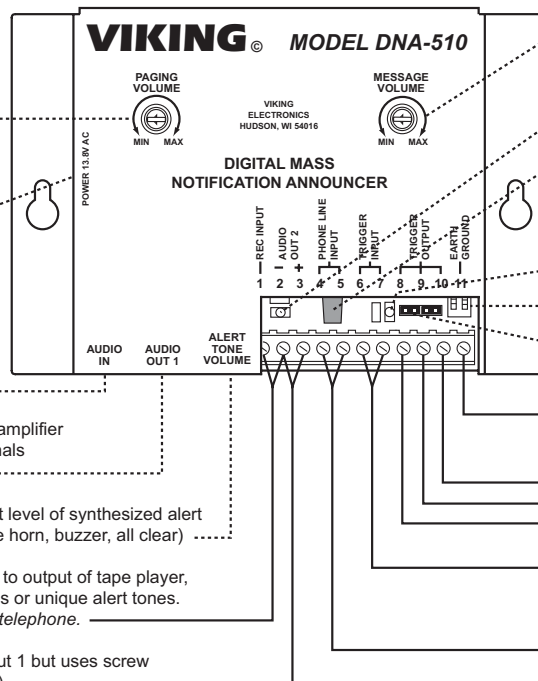

Message Volume Control - To adjust audio output level of recorded messages and pre-recorded alert tones (attack wail, alert siren, fast wail, bell)

Power Indicator LED

Mode Switch - Set to "Ring Trip" when connecting to a phone system's unused station port or dedicated phone line. Set to "Trunk" when connecting to a phone system's unused line (trunk) input port.

Page Active LED

Dip Switches - See Programming section F.

JP5 Trigger Output Selection - See Programming section K.

11: Optional Earth Ground (see **Note, pg 3)

Page Trigger Output (see Programming, K)

10: N.C. Relay Contact
9: + 12VDC / COM Relay Contact
8: - Neg / N.O. Relay Contact

6 & 7: Trigger Input - Can be configured as normally open, normally closed or disabled. Momentary or continuous contact.

4 & 5: Phone Line Input - Connect to a dedicated phone line or phone system's unused analog station port or unused line (trunk) input. See "Mode Switch" above.

Installation and Applications



IMPORTANT: Electronic devices are susceptible to lightning and power station electrical surges from both the AC outlet and the telephone line. It is recommended that a surge protector be installed to protect against such surges. Contact Panamax at (800) 472-5555 or Electronic Specialists Inc. at (800) 225-4876.

A. Connecting to a Phone Systems Unused Line (Trunk) Input, Unused Analog Station Port or to a Dedicated (POTS) Line

This application will allow you to control the **DNA-510** from any telephone on your phone system. You can simply access the phone system's line the **DNA-510** is connected to or call the phone system extension or dedicated POTS line it is connected to. The unit will automatically answer allowing you to enter a touch tone command to interrupt standard paging or background music and announce a live emergency page, start a emergency pre-recorded message or start one of ten different alert tones. **Note:** Place mode switch in "Trunk" position when connecting to a phone system's unused line input. Place mode switch in "Ring Trip" position when connecting to a phone system's unused station port or dedicated phone line.

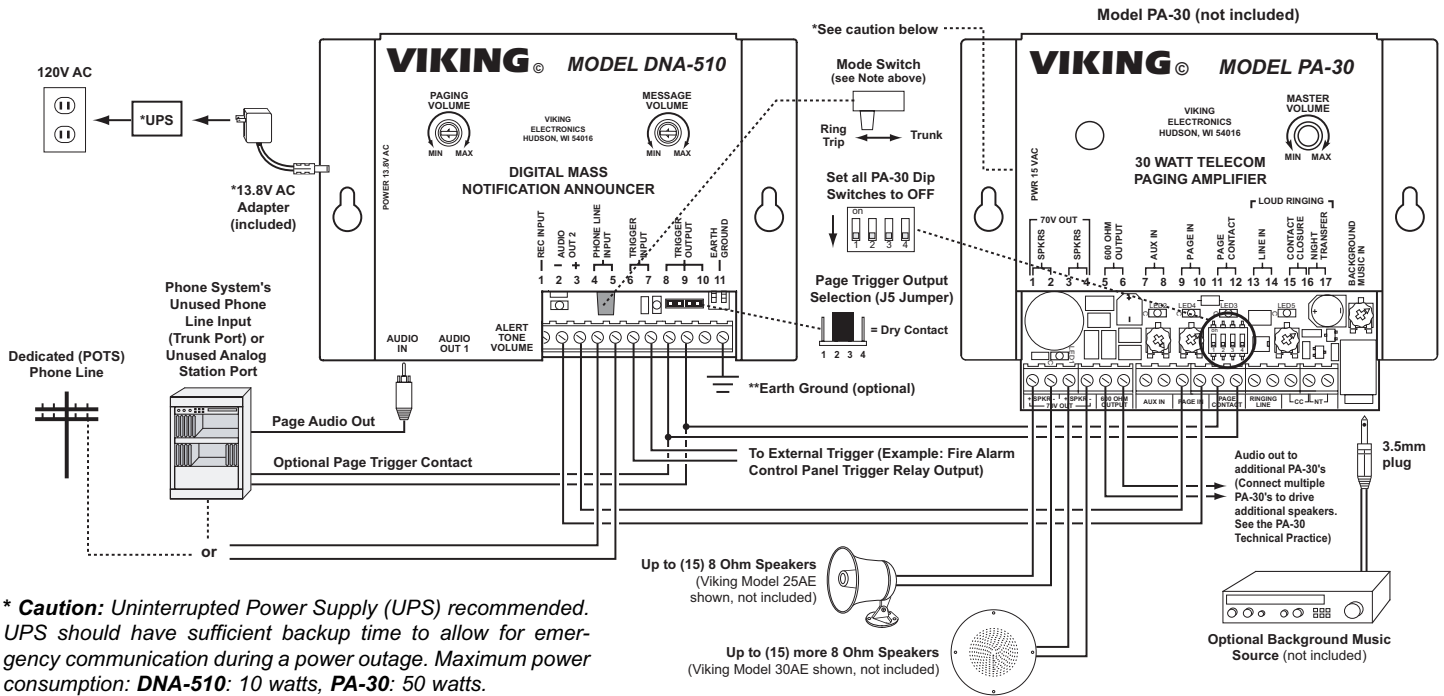

* **Caution:** Uninterrupted Power Supply (UPS) recommended. UPS should have sufficient backup time to allow for emergency communication during a power outage. Maximum power consumption: **DNA-510:** 10 watts, **PA-30:** 50 watts.

** **Note:** To increase surge protection, fasten a wire from the screw terminal to Earth Ground (grounding rod, water pipe, etc.)

B. Connecting to One or More Dedicated Telephones

This application will allow you to control the **DNA-510** from one or more dedicated (standard analog) telephones. You can simply come off-hook with any phone and enter a touch tone command to interrupt standard paging or background music and announce a live emergency page, start a emergency pre-recorded message or start one of ten different alert tones. **Note:** Place the mode switch in the "Trunk" position.

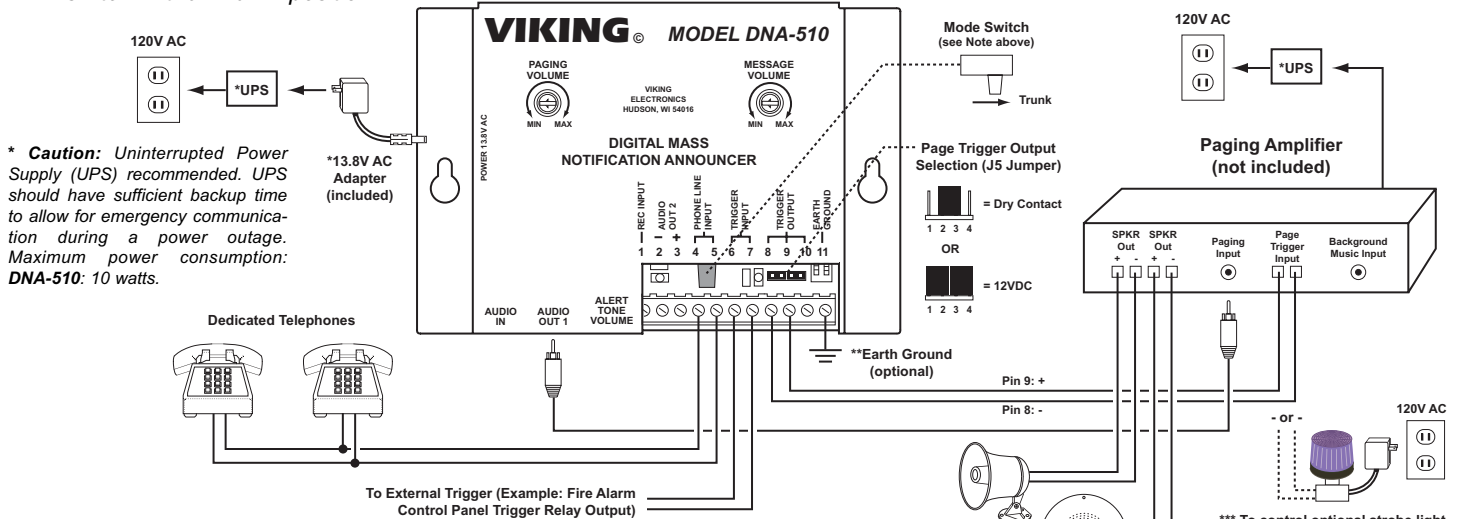

* **Caution:** Uninterrupted Power Supply (UPS) recommended. UPS should have sufficient backup time to allow for emergency communication during a power outage. Maximum power consumption: **DNA-510:** 10 watts.

** **Note:** To increase surge protection, fasten a wire from the screw terminal to Earth Ground (grounding rod, water pipe, etc.)

*** **Note:** A 390-750 Ohm 1/2 Watt resistor (not included) is required for this application. For more information, see DOD# 880.

Programming

CAUTION! Attention Installers: All programming must be thoroughly tested when installation is complete. Periodic testing at regularly scheduled intervals is recommended.

A. Accessing the Programming Mode

Note: The unit must be idle (alert tones and messages stopped) to access programming.

1. Accessing the Programming Mode Locally (Trunk Mode) with a Security Code

Step 1.	Come off-hook with any phone connected to terminals 4 & 5 PHONE LINE INPUT , 1 or 2 beeps will be heard.
Step 2.	Enter * followed by the 6-digit security code (factory set to 845464 , see Programming section B).
Step 3.	A double beep will indicate that you have accessed the programming mode.
Step 4.	You can now touch tone program the features listed in section L .
Step 5.	When finished programming, hang up.

2. Accessing the Programming Mode Locally (Trunk Mode) without a Security Code

Step 1.	Move DIP switch 1 from OFF to ON (Security Code Bypass mode, see DIP Switch Programming section G).
Step 2.	Come off-hook with any phone connected to terminals 4 & 5 PHONE LINE INPUT .
Step 3.	A double beep will indicate that you have accessed the programming mode.
Step 4.	You can now touch tone program the features listed in section L .
Step 5.	When finished programming, hang up and move DIP switch 1 back to the OFF position.

3. Accessing the Programming Mode Remotely (Ring Trip Mode)

Step 1.	Call into the DNA-510 from a touch tone phone.
Step 2.	The DNA-510 will automatically answer and provide 1 or 2 beeps.
Step 3.	Enter * followed by the 6-digit security code (factory set to 845464 , see Programming section B).
Step 4.	A double beep will indicate that you have accessed the programming mode.
Step 5.	You can now touch tone program the features listed in section L .
Step 6.	When finished programming, dial ##7 , 3 beeps should be heard, then hang up.

Note: Programming from a cell phone may not be suitable in areas with weak coverage.

B. Security Code

This six-digit number can be used to access the programming mode. The security code has been factory set to **845464** (V-I-K-I-N-G). It is recommended that you change the security code to a personal six-digit number. To change the security code, access programming (see **Programming** section **A**). Enter six digits 0-9 followed by **#47**. If you have forgotten your security code, follow the steps in **Programming** section **A, 2. Accessing the Programming Mode Locally (Trunk Mode) without a Security Code**. **Note:** The security code must be 6-digits and can **NOT** contain a * or #.

C. Access Code

This is a programmable number that must be entered to access the **DNA-510**'s touch tone operation commands. The access code can be programmed from 1-6 digits and is factory disabled. An access code is useful at installations where only select personnel are allowed to control the **DNA-510**. To program an access code, access programming (see **Programming** section **A**) then enter a 1-6 digit number followed by **#48**. With an access code programmed, as soon as you call the line the **DNA-510** is connected to (ring trip mode) or access the phone system's line input the unit is connected to (trunk mode), you will hear one beep signaling you to enter your 1-6 digit access code. If an incorrect access code is entered, the unit will output 3 beeps and you can re-enter your access code. When a correct access code is detected, 2 beeps will be heard and you can now operate the unit. **Note:** The access code must be 1-6 digits and can **NOT** contain a * or #.

D. Recording Messages

1. Recording Messages from Your Touch Tone Phone

Recording of the voice messages may be done either locally or remotely with a touch tone phone. Once programming has been entered, touch tones are used to start and stop the recording process. To start a recording: enter * followed by the message number (1-5). The **DNA-510** gives a single beep to indicate that it is recording and then starts the recording process. Speak into the handset of the telephone to record the message. The **DNA-510** has a total message record time of 2 minutes allowing for (1) up to 2-minute recordings, (2) up to 1-minute recordings, (3) up to 40-second recordings, (4) up to 30-second recordings or (5) up to 24-second recordings. When finished recording the message, enter any touch tone to stop the recording process. At this point the **DNA-510** automatically plays back the message just recorded. If the recording process goes over 2-minutes, the **DNA-510** stops the recording and starts to playback the message. To clear a single message: enter ***#** followed by the number of the input (1-5).

2. Recording Messages from an External Source (Tape player, CD, PC wav/mp3, etc.)

Pre-recorded emergency messages and/or alert tones can be recorded through the **DNA-510**'s "REC INPUT". Connect a line level (2V p-p max) source across terminals 1 and 2. Use a touch tone phone to start, stop and review recordings (see paragraph 1 above). Recording audio can be monitored through your phone's earpiece. Make several sample recordings at different volume settings from your audio source. Review the sample message audio quality to select correct source volume setting.

Note: Use caution not to speak into the handset during external source recording as unit can record telephone line audio during recording.

E. Playing Back Messages

When in programming, enter *0 followed by the message number (1-5) to playback the selected message. If a message has been cleared, 3 beeps will be heard.

F. DIP Switch Programming

Switch	Position	Description
1	OFF	Normal Operation Mode (factory setting)
1	ON	Security Code Bypass Mode (for local programming)
2	OFF	* Trigger Input Sensitivity Reduced
2	ON	Trigger Input Sensitivity Normal (factory setting)

* **Note:** Very long wire runs on the trigger input can cause false triggers. If this occurs, lower the trigger input sensitivity by placing dip switch 2 in the OFF position.

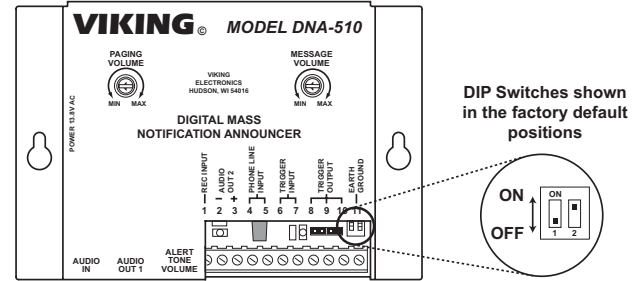

G. Message Repeat Counter

Each recorded message can be programmed to repeat 1-99 times or repeat indefinitely until manually stopped via touch tone command or trigger input control. Once programming has been entered, enter a 2-digit repeat count number 00-99 (00 = infinite) followed by the memory location #11-#15 (messages 1-5 respectively). Once a message has been triggered, the **DNA-510** will repeat that message (and pre-alert tone if programmed) until it has reached the programmed repeat count. A repeating message can also be stopped with a touch tone “#” operation command or by opening a contact closure or second momentary closure when activated from the “trigger input” (see section **J. Trigger Input** below).

H. Message Pre-Alert Tone

Each recorded message can be programmed to have one of ten different pre-alert tones (see chart below). Each pre-alert tone will be approximately 8 seconds in length and will sound prior to playing the emergency message. Once programming has been entered, enter a single digit 0-9 followed by memory location #21-#25 which correspond to message 1-5 respectively. To disable a pre-alert tone simply enter the memory location only.

Blank = Disabled (default)	3 = 8 seconds of Alert Siren	7 = 8 seconds of Bell
0 = 8 seconds of Hi/Low	4 = 8 seconds of Fast Wail	8 = 8 seconds of Buzzer
1 = 8 seconds of Code 3 Whoop	5 = 8 seconds of Fast Whoop	9 = 8 seconds of All Clear Tone
2 = 8 seconds of Attack Wail	6 = 8 seconds of March Time Horn	

I. Programmable Touch Tone Operation Commands

Each touch tone operation command 1-9 can be programmed with an alert tone, emergency message or emergency message with a pre-alert tone (see chart below). When a touch tone is entered during operation, the **DNA-510** will start playing the specific alert tone or message that has been programmed for that touch tone command. Once the programming has been entered, enter 2-digits followed by memory location #31-#39 which correspond to touch tone digits 1-9 respectively. To disable a touch tone operation command, simply enter the memory location only. **Note:** Touch tone “0” can not be programmed and is factory set to “live page”.

Blank = Disabled	05 = Fast Whoop	11 = Message 1 and Pre-Alert Tone (if programmed)
00 = Hi/Low	06 = March Time Horn	12 = Message 2 and Pre-Alert Tone (if programmed)
01 = Code 3 Whoop	07 = Bell	13 = Message 3 and Pre-Alert Tone (if programmed)
02 = Attack Wail	08 = Buzzer	14 = Message 4 and Pre-Alert Tone (if programmed)
03 = Alert Siren	09 = All Clear Tone	15 = Message 5 and Pre-Alert Tone (if programmed)
04 = Fast Wail	10 = (not used)	

Note: All alert tones continuously repeat until manually stopped with a “#” command. Messages repeat per programmed repeat counter. **Example:** To program touch tone “1” to play message 4 enter 14#31.

J. Trigger Input

The **DNA-510** has a single remote trigger input (available on terminals 6 and 7) that can be activated by a momentary or continuous normally open or normally closed contact. When the input senses a contact, the unit will start a pre-programmed alert tone, emergency message or emergency message with a pre-alert tone. The input sensitivity can be reduced (see **DIP Switch Programming** section F). The trigger input is factory set to play a repeating “code 3 Temporal Slow Whoop” from a momentary NO contact and can be stopped from a second momentary contact or by a touch tone “#” command. To program the input see **Programming** section **L Quick Programming Features** on page 6. **Note:** When programmed to activate from a continuous contact, and the repeat counter is programmed to infinite (00), the unit will continue to repeat the programmed alert tone and/or message until the contact is released or the **DNA-510** is stopped from a touch tone “#” command. Alternatively, if the repeat counter is programmed from 1-99, the message will repeat until it reaches its pre-programmed repeat count or the continuous contact has released.

K. Page Trigger Output (J5)

The **DNA-510** is factory set to output 12VDC (20mA maximum) on terminals 8 and 9 during paging, messages or alert tones. Remove both jumpers and reconnect one jumper across pins 2 and 3 to change page trigger output to a N.O./N.C. dry relay contact (1A 30V DC / 0.3A 110V AC maximum).

Page Trigger Output Selection (J5 Jumper)

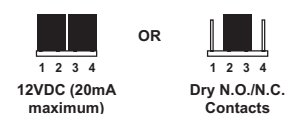

L. Quick Programming Features

Enter Digits + Memory Location

Security code (default = 845464)	6 digits (0-9)	+	#47
Access code (default = blank/disabled)	1-6 digits (0-9)	+	#48
Message memory (see chart 1 below, default: five 24-second messages)	1 digit (1-5)	+	#49

Chart 1: Message Memory (Caution: Changing this parameter erases all previously recorded messages.)

1 = (1) up to 2-minute message	3 = (3) up to 40-second messages	5 = (5) up to 24-second messages
2 = (2) up to 1-minute messages	4 = (4) up to 30-second messages	

Record messages 1-5 (press any digit to stop recording)	*1 - *5		
Playback messages 1-5 (press any digit to stop message playback)	*01 - *05		
Clear messages 1-5	*#1 - *#5		
Message 1 repeat counter (00-99, 00 = infinite, default = 00)	2 digits (0-9)	+	#11
Message 2 repeat counter (00-99, 00 = infinite, default = 00)	2 digits (0-9)	+	#12
Message 3 repeat counter (00-99, 00 = infinite, default = 00)	2 digits (0-9)	+	#13
Message 4 repeat counter (00-99, 00 = infinite, default = 00)	2 digits (0-9)	+	#14
Message 5 repeat counter (00-99, 00 = infinite, default = 00)	2 digits (0-9)	+	#15
Message 1 pre-alert tone (see chart 2, default = blank/disabled)	1 digit (0-9)	+	#21
Message 2 pre-alert tone (see chart 2, default = blank/disabled)	1 digit (0-9)	+	#22
Message 3 pre-alert tone (see chart 2, default = blank/disabled)	1 digit (0-9)	+	#23
Message 4 pre-alert tone (see chart 2, default = blank/disabled)	1 digit (0-9)	+	#24
Message 5 pre-alert tone (see chart 2, default = blank/disabled)	1 digit (0-9)	+	#25

Chart 2: Pre-Alert Tone

Blank = Disabled (default)	3 = 8 seconds of Alert Siren	7 = 8 seconds of Bell
0 = 8 seconds of Hi/Low	4 = 8 seconds of Fast Wail	8 = 8 seconds of Buzzer
1 = 8 seconds of Code 3 Whoop	5 = 8 seconds of Fast Whoop	9 = 8 seconds of All Clear Tone
2 = 8 seconds of Attack Wail	6 = 8 seconds of March Time Horn	

Touch tone "1" operation command (message or alert tone - see chart 3, default = Code 3 Whoop) ...	2 digits (00-15)	+	#31
Touch tone "2" operation command (message or alert tone - see chart 3, default = Attack Wail)	2 digits (00-15)	+	#32
Touch tone "3" operation command (message or alert tone - see chart 3, default = Alert Siren)	2 digits (00-15)	+	#33
Touch tone "4" operation command (message or alert tone - see chart 3, default = Fast Wail)	2 digits (00-15)	+	#34
Touch tone "5" operation command (message or alert tone - see chart 3, default = Fast Whoop)	2 digits (00-15)	+	#35
Touch tone "6" operation command (message or alert tone - see chart 3, default = March Time)	2 digits (00-15)	+	#36
Touch tone "7" operation command (message or alert tone - see chart 3, default = Bell)	2 digits (00-15)	+	#37
Touch tone "8" operation command (message or alert tone - see chart 3, default = Buzzer)	2 digits (00-15)	+	#38
Touch tone "9" operation command (message or alert tone - see chart 3, default = All Clear)	2 digits (00-15)	+	#39

Note: Touch tone "0" is not programmable and is factory set to "live page".

Chart 3: Programmable Touch Tone Operation Commands

Blank = Disabled	05 = Fast Whoop	11 = Message 1 and Pre-Alert Tone (if programmed)
00 = Hi/Low	06 = March Time Horn	12 = Message 2 and Pre-Alert Tone (if programmed)
01 = Code 3 Whoop	07 = Bell	13 = Message 3 and Pre-Alert Tone (if programmed)
02 = Attack Wail	08 = Buzzer	14 = Message 4 and Pre-Alert Tone (if programmed)
03 = Alert Siren	09 = All Clear Tone	15 = Message 5 and Pre-Alert Tone (if programmed)
04 = Fast Wail	10 = (not used)	

Note: All alert tones continuously repeat until manually stopped with a "#" command. Messages repeat per programmed repeat counter. Example: To program touch tone "1" to play message 4, enter: **14 #31**.

Trigger input (see chart 4 below)	4 digits	+	#40
---	-----------------	---	------------

Chart 4: Trigger Input

First Digit: 0 = N.O. contact (default), 1 = N.C. contact, 2 = Disabled
Second Digit: 0 = Momentary contact (default), 1 = Continuous contact
Third and Fourth Digits:

00 = Hi/Low	06 = March Time Horn	11 = Message 1 and Pre-Alert Tone (if programmed)
01 = Code 3 Whoop (default)	07 = Bell	12 = Message 2 and Pre-Alert Tone (if programmed)
02 = Attack Wail	08 = Buzzer	13 = Message 3 and Pre-Alert Tone (if programmed)
03 = Alert Siren	09 = All Clear Tone	14 = Message 4 and Pre-Alert Tone (if programmed)
04 = Fast Wail	10 = (not used)	15 = Message 5 and Pre-Alert Tone (if programmed)
05 = Fast Whoop		

Note: When trigger input is set to continuous and the message repeat counter is set to infinite, the message (and pre-alert tone if programmed) will repeat until contact is removed.

Forced hang-up	##7
Reset all programming to factory default settings	###

Operation

To control the **DNA-510** simply call the telephone line, phone system station port or access the phone system's line input (trunk) the unit is connected to. At this point you should hear one or two beeps. Two beeps will indicate the access code has been disabled and you can now operate the unit. A single beep will signal you to enter your pre-programmed access code (1-6 digits), when a correct access code is detected, two beeps will be heard and you can now operate the unit. Three beeps indicate an incorrect code. Once in the operation mode you can enter a touch tone command which will allow you to start a live page or start and stop any of the pre-programmed alert tones and/or message (see chart below). **Note:** *If you have accessed the **DNA-510** remotely (ring trip mode), you will be allowed up to 20 seconds between touch tone command entries. If more than 20 seconds has elapsed, the **DNA-510** will automatically hang up.*

A. Pre-Programmed Alert Tones and/or Messages

Dial	Description
0	Live Page (default, not programmable)
1	Play programmed Message and/or Alert Tone (default = Code 3 Whoop)
2	Play programmed Message and/or Alert Tone (default = Attack Wail)
3	Play programmed Message and/or Alert Tone (default = Alert Siren)
4	Play programmed Message and/or Alert Tone (default = Fast Wail)
5	Play programmed Message and/or Alert Tone (default = Fast Whoop)
6	Play programmed Message and/or Alert Tone (default = March Time Horn)
7	Play programmed Message and/or Alert Tone (default = Bell)
8	Play programmed Message and/or Alert Tone (default = Buzzer)
9	Play programmed Message and/or Alert Tone (default = All Clear Tone)
#	Stop any message, alert tone or live page (default, not programmable)

B. Alert Tone Descriptions

Alert Tone	Description
Hi/Low Siren	633Hz/457Hz alternating every 800msec.
Code 3 Temporal Slow Whoop (ANSI S3.41)	0.5 sec sweep from 200Hz-700Hz, pause 0.5 sec, repeat 3 times then pause for 1.5 sec and repeat total cadence. Cadence complies with ANSI S3.41.
*Attack Wail	Air raid siren recording: 2 second rise to 5 seconds of steady siren then decay for 5 seconds, repeat. Loop every 13 seconds.
*Alert Siren	Severe weather siren recording: 2 second rise to steady siren. Loop steady siren every 11 seconds.
*Fast Wail	Siren recording: 1.5 second rise and decay, repeat. Loop every 8 seconds.
Fast Whoop	Fast repeating up sweep: 600Hz-1200Hz with 1 second rise, repeat.
March Time Horn	Fast on/off horn: 400Hz/700Hz 0.25 sec on, 0.25sec off, repeat.
*Bell	Alarm system bell recording: Loop every 8 seconds.
Buzzer	120Hz/240Hz, steady.
All Clear Tone	1KHz steady tone.

* **Note:** *Looping recordings of actual emergency sirens and alarm bell.*

C. Programming Chart

To help simplify programming, write all of the programming numbers below. See section **F. Quick Programming Features** page 5.

Security Code: _____ + #47

Access Code: _____ + #48

Message memory: _____ + #49

Message 1 repeat counter: _____ + #11

Message 2 repeat counter: _____ + #12

Message 3 repeat counter: _____ + #13

Message 4 repeat counter: _____ + #14

Message 5 repeat counter: _____ + #15

Message 1 pre-alert tone: _____ + #21

Message 2 pre-alert tone: _____ + #22

Message 3 pre-alert tone: _____ + #23

Message 4 pre-alert tone: _____ + #24

Message 5 pre-alert tone: _____ + #25

Touch tone "1" operation command: _____ + #31

Touch tone "2" operation command: _____ + #32

Touch tone "3" operation command: _____ + #33

Touch tone "4" operation command: _____ + #34

Touch tone "5" operation command: _____ + #35

Touch tone "6" operation command: _____ + #36

Touch tone "7" operation command: _____ + #37

Touch tone "8" operation command: _____ + #38

Touch tone "9" operation command: _____ + #39

Trigger input: _____ + #40

D. User Recorded Message Script Examples

The following are some examples of messages which may be recorded in the field:

Fire 1	"May I have your attention please. May I have your attention please. The signal you have just heard indicates a report of a fire in this building. Please proceed to the nearest exit and leave the building. Do not use the elevators. Do not re-enter the building unless directed to do so by the proper authorities."
Fire 2	"May I have your attention please. May I have your attention please. A fire emergency has been reported in the building. A fire emergency has been reported in the building. Please proceed to the stairways and exit the building. Do not use the elevators, but proceed to the stairways and exit the building."
Fire 3	"May I have your attention please. May I have your attention please. A fire emergency has been reported on your floor. A fire emergency has been reported on your floor. Please proceed to the stairways and exit the building. Do not use the elevators."
Emergency Condition	"May I have your attention please. May I have your attention please. An emergency condition exists in this building. An emergency condition exists in this building. Please proceed to the stairways and exit the building. Do not use the elevators."
Lockdown	"May I have your attention please. May I have your attention please. An armed intruder is in the building. Lock all doors and take cover."
Severe Weather	"Your attention please. A severe weather warning has been received. Please walk to the nearest safe area and wait for further instructions. Elevator lobbies, stairwells, bathrooms and auditoriums are designated safe areas in the event of severe weather. Stay away from windows and glass. Do not use the elevators."
Tornado	"May I have your attention please. May I have your attention please. A tornado warning has been issued for this area. A tornado warning has been issued for this area. Please take all appropriate safety actions at this time."
Hurricane	"May I have your attention please. May I have your attention please. A hurricane warning has been issued for this area. A hurricane warning has been issued for this area. Please take all appropriate safety actions at this time."
Chemical Release	"Attention chemical release. Stay inside buildings and close windows and doors unless advised by authorities to evacuate the area. Attention chemical release. Stay inside buildings and close windows and doors unless advised by authorities to evacuate the area. Chemical release."
Test	"May I have your attention please. This is a test of the emergency warning system. This is only a test. This is a test of the emergency warning system. This is only a test."
All Clear	"Attention. Your attention please. The building emergency condition has been cleared. You may return to your normal activities. The building emergency has been cleared. You may return to your normal activities."

E. Operation Commands

Use the chart to the right to fill in the number to be dialed or line to access. Access Code (if programmed) and all pre-programmed operation commands. Make photocopies of the chart and place near each phone that may use the **DNA-510**.

Emergency Notification System Operation Commands

Viking Model DNA-510

Dial: _____

Enter Access Code: _____

Enter a digit to activate the following:

0 Live Page _____

1 _____

2 _____

3 _____

4 _____

5 _____

6 _____

7 _____

8 _____

9 _____

Stop Message, Alert Tone or Page _____

Product Support Line...715.386.8666

Fax Back Line...715.386.4345

Due to the dynamic nature of the product design, the information contained in this document is subject to change without notice. Viking Electronics, and its affiliates and/or subsidiaries assume no responsibility for errors and omissions contained in this information. Revisions of this document or new editions of it may be issued to incorporate such changes.