

Add Time Controlled Alert Tones and Emergency Tones to Your Paging System



Viking's model **CTG-1** is a clock controlled tone generator designed to provide accurately timed bong alert tones or buzzer alert tone sounds over an existing paging system.

The **CTG-1** can be programmed to output single, double or triple alert tones with up to 128 events in a 24 hour period. These bong/buzzer sounds are ideal for indicating the start and end of shifts, break times, lunch periods, etc. for factories, schools, or any business

requiring an audible indication of specified times. Each day of the week can be programmed to either on or off, allowing you to turn off the alert tones during specific days of the week (weekends, etc.)

The **CTG-1** has three contact closure inputs for triggering an emergency siren, evacuation signal or a doorbell sound.

Features

- Accurate 24 hour digital time clock displays hours and minutes
- User programmable 24 hour, 128 event timer
- Programmable day of week on/off feature
- Programmable single, double or triple alert tone output (selectable bong or buzzer)
- Three contact closure controlled sounds:
 - 1) Emergency siren (yelp) sound
 - 2) Temporal (slow whoop) evacuation signal
*NFPA/ANSI compliant when used with supporting equipment
 - 3) Doorbell (chime) sound
- Volume controllable, 600 ohm line level audio output
- Non-volatile programming memory
- Battery backup for maintaining clock time with factory installed 9V NiMh rechargeable battery
- Two sets of DPDT relay contacts for muting paging or background music during alert tones

Applications

- Signal the beginning and end of class periods, breaks, and lunch periods for schools
- Signal the beginning and end of shifts, breaks, and lunch periods for factories and other businesses
- Provides a doorbell and/or alarm sounds over an existing paging system, for such applications as door entry, fire, severe weather, etc.
- Use with Viking's **DVA-2WA** to provide timed messages (**Fax Back Document 110**)

Phone... 715.386.8861

<http://www.vikingelectronics.com>

Specifications

Power: 120V AC/13.8V AC 1.25A UL listed adapter provided
Dimensions: 133mm x 91mm x 44mm (5.25" x 3.6" x 1.75")
Weight: 0.9 Kg (2 lbs)
Environmental: 0°C to 32°C (32°F to 90°F) with 5% to 95% non-condensing humidity
Connections: 12 position cage clamp terminal strip
Battery Backup: 9V NiMh rechargeable battery (factory installed) maintains clock time for over 8 hours
Time Base: 60Hz AC power line
Time Base Battery Backup Accuracy: +/- 50 ppm
Audio Output: 600 ohm with volume adjust potentiometer, maximum level = 17 dBm/5.4Vrms across 600 ohm load
Relay Output: DPDT rated 125V AC, 30 W (resistive load)

Features Overview

Mode Button: Press to place the CTG-1 in the Lock, Set Time, Set Day, Set Events or Review/Cancel modes.

Clock and Event Time Setting Buttons: Press the + or -/CANCEL buttons to increase or decrease time. The -/CANCEL switch is also used to cancel an alert tone event when reviewing programming.

Alert Tones Programming Buttons: After setting an event time, press SINGLE, DOUBLE or TRIPLE to program 1, 2 or 3 alert bongs/buzzer sounds for that event time.

Secondary Button Functions While in the SET DAY Mode: The SINGLE button is used to select between day (1-7) or on/off. The DOUBLE button is used as a one time setup to program today's day of the week.

9V Battery Backup Connection: A standard rechargeable (NiMh) 9V battery is installed to maintain the clock time during power outages.

CTG-1 Output Volume Control: Turn clockwise to increase volume of alert bongs/buzzer sounds, emergency and door bell (chime) sounds (see diagram below).

*** Note:** When the buzzer alert tone is programmed, a double or triple programmed event will be sounded twice, approximately three seconds apart.

Display: Shows clock, event time and mode settings.

DIP Switches: See Programming section J.

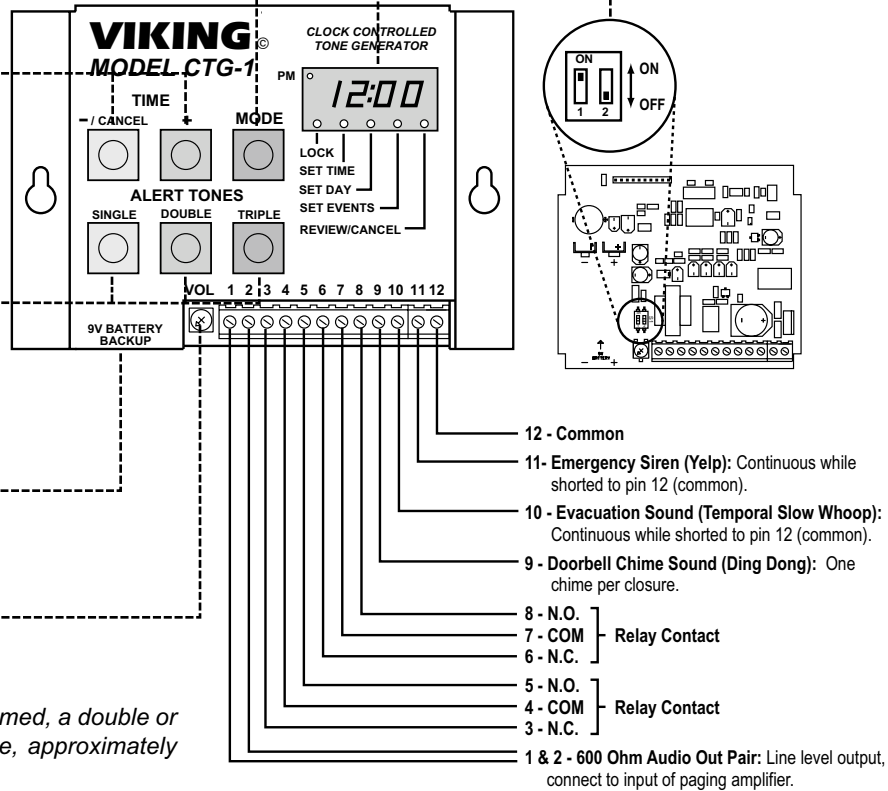

- 12 - Common
 - 11 - Emergency Siren (Yelp): Continuous while shorted to pin 12 (common).
 - 10 - Evacuation Sound (Temporal Slow Whoop): Continuous while shorted to pin 12 (common).
 - 9 - Doorbell Chime Sound (Ding Dong): One chime per closure.
 - 8 - N.O.
 - 7 - COM
 - 6 - N.C.
 - 5 - N.O.
 - 4 - COM
 - 3 - N.C.
- Relay Contact (for pins 6-8 and 3-5)
- 1 & 2 - 600 Ohm Audio Out Pair: Line level output, connect to input of paging amplifier.

Installation

Connect the CTG-1 between your phone system and your paging amplifier as shown in the diagram below. The factory installed rechargeable 9V battery will maintain the clock time for over 8 hours.

IMPORTANT: The CTG-1 leaves the factory with the battery backup DIP switch turned OFF to avoid discharging the battery during shipment. The battery backup DIP switch **MUST** be set to ON (see Programming section J) to maintain clock time during a power outage.

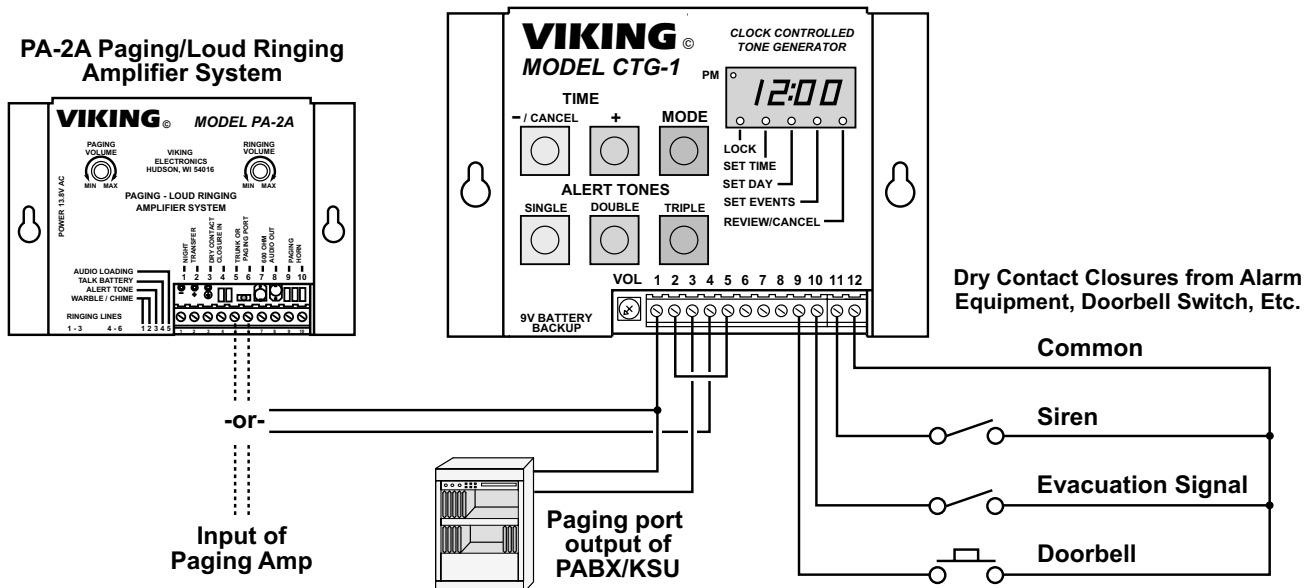

Programming

A. Setting the Clock Time

1. Press the **MODE** button repeatedly until the **SET TIME** indicator lights.
2. Increase or decrease the clock time by pressing the **+** or **-/CANCEL** button until the desired time is displayed.
3. Leave the set time mode by pressing the **MODE** button.

Note: Either the **+** or **-/CANCEL** button **MUST** be pressed at least once prior to leaving the set time mode. The clock will then start to run the moment you leave the set time mode, allowing you to synchronize the **CTG-1** with your building clocks.

B. Setting the Day of the Week

Note: This step is only required if you want to turn off the Alert Tones on certain days of the week.

1. Press the **MODE** button repeatedly until the **SET DAY** indicator lights.
2. A flashing **"A"** indicates all 7 days of the week are **"on"** and today's day has not been set. The day of the week has already been set if a flashing number (1-7) and **"on"** or **"of"** are displayed.
3. Select today's day of the week using the **TIME (+ and -/CANCEL)** buttons. As a general rule, Sunday is day 1 and Saturday is day 7. When today's day of the week is flashing on the display, set it by pressing the **DOUBLE** alert tone button. Today's day number and **"on"** will now be displayed.

Note: The day of the week setting and turning the alert tones off on specific days of the week is a one time set up and does not need to be reset unless you have experienced a brown out long enough to discharge the 9V battery backup (approximately 8 hours). To reset the day of the week and turn off tones on specific days of the week, you must power down the **CTG-1**, set DIP switch 1 to **OFF**, power up the **CTG-1** and repeat steps 1-3 above. If you had alert tones turned off on specific days of the week, repeat steps 1-4 in section **C** below. When finished, set DIP switch 1 back to **ON**.

C. Turning the Alert Tones On/Off for Specific Days of the Week

1. Press the **MODE** button repeatedly until the **SET DAY** indicator lights. The current day of the week and **"on"** or **"of"** will be displayed. **"on"** = alert tones are ON and **"of"** = alert tones are OFF for that day of the week.
2. Pressing the **SINGLE** button will toggle between flashing the day of the week and flashing **"on"** or **"of"**. The flashing portion of the display is the section that can be changed.
3. With the day of the week flashing, use the **TIME (+ and -/CANCEL)** buttons to select the day of the week you would like to set to ON or OFF. When the correct day of the week is displayed, press the **SINGLE** button to flash **"on"** or **"of"**. The day can then be set to ON or OFF by using the **TIME (+ and -/CANCEL)** buttons.
4. Review your day of the week programming by pressing the **SINGLE** button until the weekday (1-7) is flashing, then increment through each day of the week with the **TIME (+)** button and monitor each day for its on or off setting. Exit the **SET DAY** mode by simply pressing the **MODE** button.

D. Setting Timed Alert Tones

1. Press the **MODE** button repeatedly until the **SET EVENTS** indicator lights.
2. Increase or decrease the event time by pressing the **TIME (+ or -/CANCEL)** button until the desired time is shown.
3. Move DIP switch 2 to **OFF** for bong alert tones or **ON** for buzzer alert tones (see **Programming** section **J**).
4. Press one of the single, double, or triple **ALERT TONES** buttons to program the number of alert tones you wish to output at the specific event time. A single, double, or triple confirmation beep should be heard.
5. Repeat steps 2-4 for the remainder of your scheduled events.

Note: If more than 128 events have been entered, a long beep will be heard indicating that the event memory is full.

E. Reviewing and/or Cancelling Timed Alert Tones

1. Press the **MODE** button repeatedly until the **REVIEW/CANCEL** indicator lights.
2. Press one of the **ALERT TONES** buttons (single, double, or triple) repeatedly to rotate through the event times associated with that alert tone button. A red LED at the bottom right corner of the time display will light to indicate a buzzer event time (versus a bong event).

Note: Event times are stored in the order of programming, not chronologically.

3. Press the **-/CANCEL** button to permanently cancel an event tone. A single acknowledgement tone will be heard. The next consecutive event for that specific alert tone will then be displayed.
4. Repeat steps 2-3 as needed to remove the events to be cancelled.
5. When all events for a given alert tone have been cancelled, the display shows three dashes (- - -).

F. Adjusting Output Volume

1. Short pins **9** and **12** together momentarily. The doorbell sound will then chime once.
2. Adjust the volume control potentiometer (see **Installation**).
3. Repeat steps 1-2 until the desired volume is achieved.

G. Activating Contact Closure Alarm Tones

To activate different sounds, short the corresponding pins with a dry contact closure as shown right (see **Installation**, section **A**). **Note:** The evacuation sound and siren will be repeated continuously, as long as the closures are maintained.

Sound	Short Pins...
Doorbell (Ding Dong)	...9 to 12
Evacuation Sound (Slow Whoop)	...10 to 12
Siren (Yelp)	...11 to 12

H. Locking the CTG-1 for Operation

When finished programming, press the **MODE** button until the **LOCK** indicator lights. In the lock mode, the time and alert tone keys will be disabled and the current time will be displayed with the colon flashing once per second.

I. Clearing the Alert Tone Memory

Turn DIP switch **1** **OFF**. Unplug the **CTG-1** from power. Pause a few seconds and then plug the **CTG-1** back in. Push the **CANCEL** and **SINGLE** buttons at the same time and release them. Repeat, and after releasing the buttons the second time a long beep will be heard indicating that the **CTG-1**'s memory has been cleared. Turn DIP switch **1** back **ON** to enable battery backup. **Note:** After completing this procedure, it will be necessary to reset the clock time (see **Programming** section **A**), and if enabled, the day of the week (see **Programming** section **B**) and alert tones on/off (see **Programming** section **C**).

J. DIP Switch Settings

Switch	Position	Description
1	OFF	Battery backup disabled
1	ON	Battery backup enabled
2	OFF	Bong alert tones (factory setting)
2	ON	Buzzer alert tones

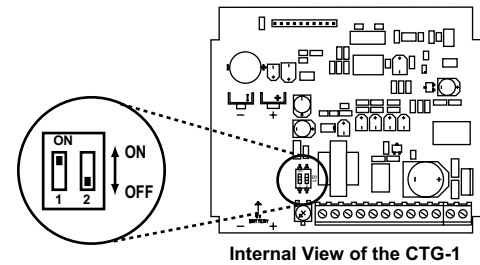

Operation

When the clock time matches an event time and that day is set to "ON" or "A", the **CTG-1** will output the corresponding single, double or triple bong or buzzer alert tone. The **CTG-1** will also open terminals 3 and 4 (normally closed) and close terminals 4 and 5 (normally open), allowing the capability of switching out the audio from the phone system and switching in the alert tone from the **CTG-1**. Similarly, while a contact closure is made shorting pins 9, 10 or 11 to pin 12, the **CTG-1** will output the corresponding sound (doorbell, evacuation signal or emergency siren). In the case of the siren or evacuation signal, terminals 3 and 4 will open, and terminals 4 and 5 will close and the sound will continue for the duration of the contact closure input. Terminals 3, 4 and 5 will return to their normal states at the end of each doorbell tone. **Note:** Terminals 6, 7 and 8 will operate the same as terminals 3, 4 and 5 but are electronically isolated from terminals 3, 4 and 5 for switching a separate device.

IMPORTANT: While operating, the **CTG-1** continuously checks the event time information stored in memory. If a problem is detected, the **CTG-1** displays "EEE" to indicate an error. Normal clock function continues in the background. To clear the error, press any button and the **CTG-1** will return to normal operation. If the "EEE" display persists, contact Viking Technical Support at 715-386-8666.

Sound Output Specifications

A. Bong Alert Tone

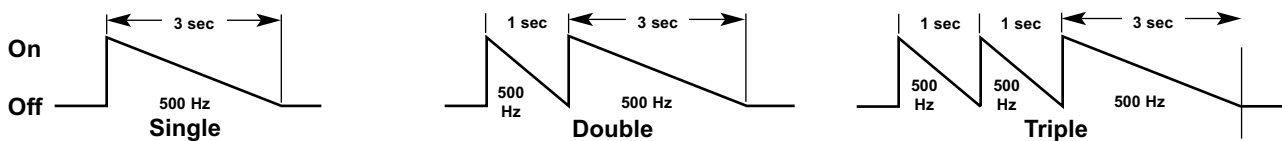

B. Buzzer Alert Tone

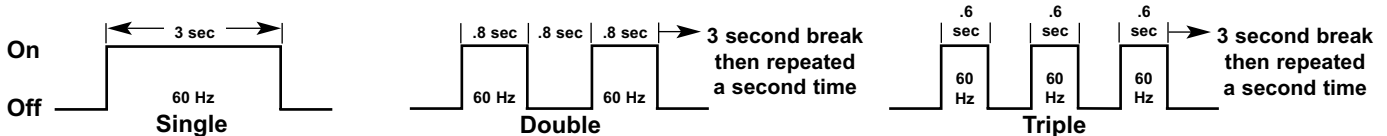

C. Doorbell (Ding Dong)

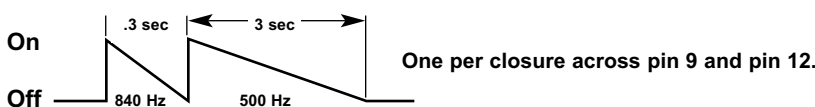

D. Evacuation Signal (Temporal Slow Whoop)

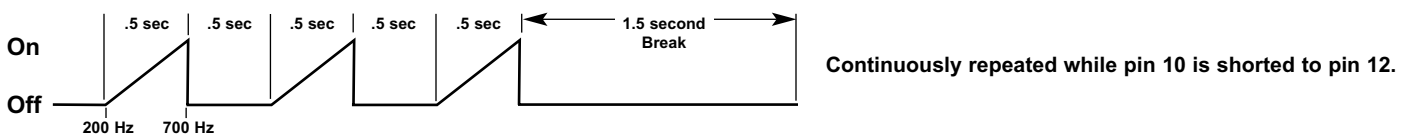

E. Siren (Yelp)

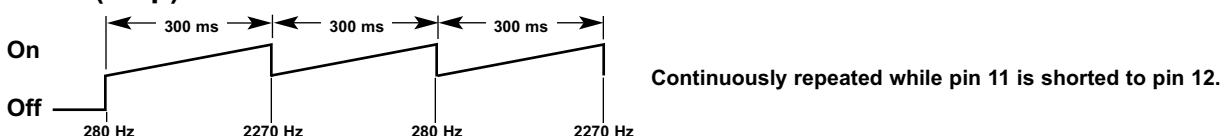

Product Support Line...715.386.8666

Fax Back Line...715.386.4345

Due to the dynamic nature of the product design, the information contained in this document is subject to change without notice. Viking Electronics, and its affiliates and/or subsidiaries assume no responsibility for errors and omissions contained in this information. Revisions of this document or new editions of it may be issued to incorporate such changes.