



TECHNICAL Practice

TELECOM SOLUTIONS FOR THE 21ST CENTURY

ACD-10
**Automatic Call
Distributor**

July 6, 2004

Now Every Call Center and Small Business Can Afford a Fully Featured Call Distributor

The **ACD-10** is a stand alone call distributor that will distribute calls from up to 10 incoming C.O./PABX lines to up to 6 individual agents.



Calls will be distributed by either ACD (Automatic Call Distributor), UCD (Uniform Call Distributor), hunt group or ring group protocols.

If an agent is not available, the **ACD-10** can be programmed to answer calls,

play an announcement, and place the call on hold for the first available agent. Custom ringing indicates to the agent that the call has been answered by the **ACD-10**.

Basic phone system features are also provided by the **ACD-10** such as transfer, paging, intercom, 3-way calling, as well as a RS-232 call statistics output.

For "Specifications" see Page 2.

Features

Stand-Alone Unit:

- Does not require a KSU, PABX, ring generator or remote displays

Custom Recordings:

- On site or from a remote touch tone phone
- **Day Answer** announcement (up to 30 seconds)
- **Night Answer** announcement (up to 60 seconds)
- **Pacifier** announcement (up to 10 seconds)

Answer Modes:

- **Standard** - Answers if the agent does not answer within the programmable ring delay (3 or 5), plays an announcement, then places the caller on hold with music or promotion from an external source.
- **Call Screening** - Answers all calls after 1 or 2 rings, plays an announcement, such as: "Viking Electronics, your calls may be monitored for quality purposes."

Operational Modes:

- **ACD** (Automatic Call Distributor) - Calls are sent to the next available or longest idle agent.
- **UCD** (Uniform Call Distributor) - Calls are distributed so that each agent receives approximately the same number of calls.
- **Hunt Group** - Agent #1 receives the most calls, Agent #2 receives calls only if Agent #1 is busy, etc.
- **Ring Group** - All agent phones ring, the first to pick up gets the call.

Other Features

- **Agent Unavailable** - Agent marks his station unavailable by dialing a code or simply leaving the phone off-hook. In the event that an agent's phone rings more than the programmed ring limit, the system marks the station unavailable and sends the call to another agent.
- **Announcements and Programming** - Stored in non-volatile memory
- **Blind Transfer** - An agent can transfer a call to another agent without telling the agent who's calling
- **Break Delay Time** - Allows agent to "catch their breath" before receiving a new call
- **Camp-On** - Agents can camp-on a call to another agent who is on an existing call

- **Conference** - Agents may conference in a second agent
- **Custom Ringing** - A double ring indicates a system answered or intercom call, a single ring indicates the call is from the CO or PABX (not answered)
- **Directed Call Pick-Up** - Pick up any agent's phone from your phone
- **Disconnects on CPC** - (CPC may not be available in all PABX's)
- **Intercom** - Agents can call each other
- **MOH Input** (Music-On-Hold) - Connection for an audio source that callers on hold hear while waiting for an available agent
- **Night Answer** - Announcement and drop or no answer at night
- **Night Mode Turns ON/OFF** - via a contact closure, remote touch tone phone, or front panel switch
- **Outbound** - Agents can dial 9 or dial a "Direct Trunk Access Code" for an outbound line
- **Paging** - Agents can voice page over external PA speakers
- **Park** - Agents can put a call on hold and busy out their phone
- **Recording** - Locally using the included carbon handset, download from a tape recorder, or remotely from a touch tone phone
- **Security Code** - A 6-digit number used to access programming
- **Station Active LED Indicators** - Displays which agents are busy
- **Statistics** - A RS-232 port provides a printer or PC with data of: time, date, line, hold time, agent, agent time and type for each call
- **Supervised Transfer** - An agent can transfer a call to another agent by first conversing with the agent, then hang up to give them the call
- **Transfer Out of System** - Allow agents to use Centrex or PABX 3-way calling/transfer feature to send calls to another location

Applications

- Call centers
- Sales departments
- Field service departments
- Technical support departments
- Small businesses

Specifications

Power: 120V AC/15V AC 2.2A, UL listed adapter provided
Dimensions: 483mm x 305mm x 44mm (19" x 12" x 1.75")
Shipping Weight: 3.4 kg (7.5 lbs)
Environmental: 0° C to 32° C (32° F to 90° F) with 5% to 95% non-condensing humidity
Station Loop Length: 1.5 km (5000 ft) maximum at 24 AWG twisted pair
Station Talk Battery Voltage: 40V DC 26mA
Station Ring Voltage: 90V AC @ 20 Hz (nominal)
Hookswitch Flash Timing Range: 150ms - 900ms

Internal Digital Announcer/Recorder: 1
Message Lengths: Day message - 30 seconds, Night message - 60 seconds, Pacifier message - 10 seconds
Announcement Sampling Rate: 64K (equivalent)
Intercom Paths: 2
Dial Tone with DTMF Receiver: 1
Camp-On Calls: Up to 2 calls per station
Audio Loss: 2 dB from trunk to station
Connections: (1) RJ-21X female jack, (4) 3.5mm (1/8") audio jacks, (1) carbon handset jack, (1) 9-pin RS-232 jack, (2) screw terminals

Installation

IMPORTANT: Electronic devices are susceptible to lightning and power station electrical surges from both the AC outlet and the telephone line. It is recommended that a surge protector be installed to protect against such surges. Contact Panamax at (800) 472-5555 or Electronic Specialists Inc. at (800) 225-4876.

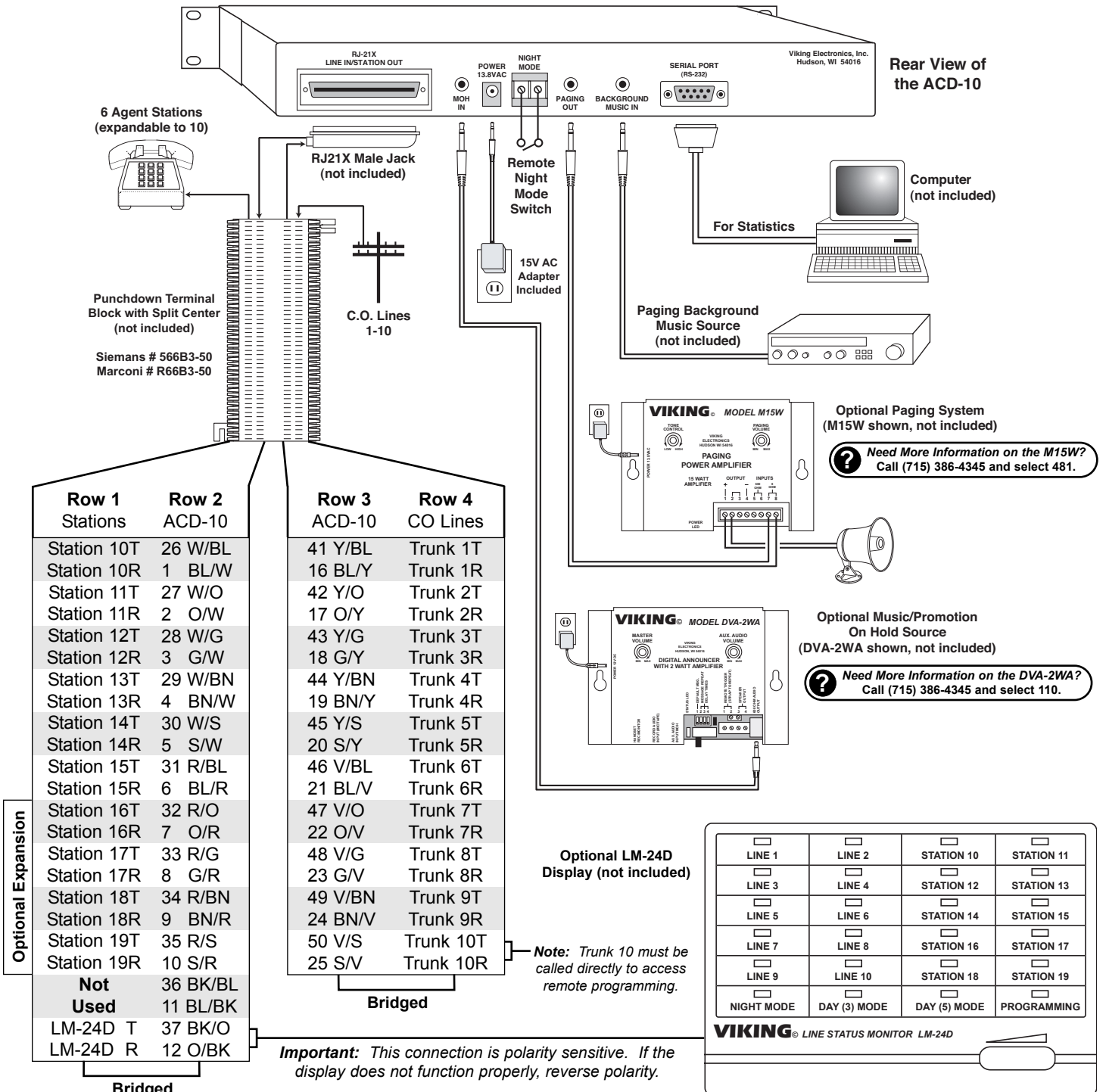

Programming

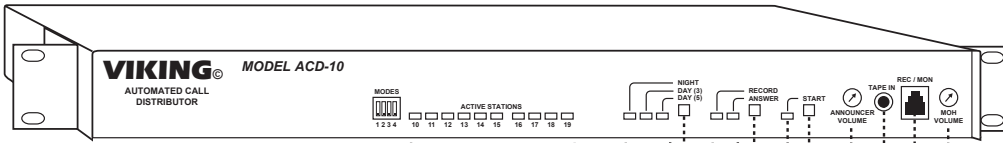

- Station "In-Use" Indicators
- Answer Mode Indicators
- Answer Mode Selector
- Local Record Indicators
- Local Record Selector
- Music-On-Hold Volume Control
- Carbon Handset Jack
- Tape/CD/Sound card Input
- Announcement Volume Control
- Start/Stop Record/Play Button
- Start Indicator

A. DIP Switch Programming

Sw 1	Sw 2	Sw 3	Sw 4	Description
OFF	OFF	n/a	n/a	ACD Operation
OFF	ON	n/a	n/a	UCD Operation
ON	OFF	n/a	n/a	Hunt Group Operation
ON	ON	n/a	n/a	Ring Group Operation
n/a	n/a	OFF	n/a	Normal mode: Answers call if agent does not answer within 3-5 rings (programmable).
n/a	n/a	ON	n/a	Call screening mode: Answers all calls and plays message before calls ring through to agent.
n/a	n/a	n/a	OFF	No calls answered in the "night mode". (line 10 will answer after 10 rings for remote programming)
n/a	n/a	n/a	ON	Calls are answered, given the night announcement and dropped when in the "night mode".

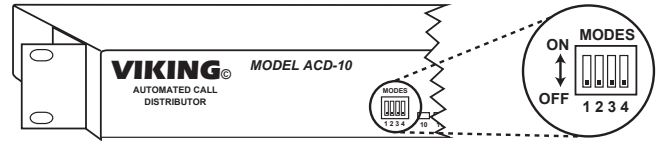

B. Security Code

A six-digit number must be used to access the programming mode. The security code has been factory set to **845464** (V-I-K-I-N-G). It is recommended that you change the security code to a personal six-digit number as follows:

Step 1.	Access programming as shown in section D below.
Step 2.	Enter your new security code, followed by "#47" .
Note: The security code must be six-digits in length and cannot contain a * or #.	

C. Accessing the Programming Mode

Step 1.	Call into line 10 using a Touch Tone phone.
Step 2.	When answered by an attendant, enter a *. If answered by the ACD-10 , press and hold * until the message stops.
Step 3.	When the recording stops, enter the six digit security code. A double beep should be heard.

D. Recording and Playback

Note: Keep recorded announcements short. The **ACD-10** cannot answer additional calls while any announcement is playing.

1. Local

Step 1.	Plug the supplied carbon handset into the REC/MON jack or plug a tape player into the TAPES IN jack (see diagram).
Step 2.	Select the record mode by pressing the RECORD/ANSWER switch until the LED light indicates the record mode is selected (see diagram above)
Step 3.	Select the announcement to be recorded (Answer Greeting, Pacifier or Night) by pressing the NIGHT/DAY(3)/DAY(5) button until the LED indicates the desired announcement (see diagram above). NIGHT - Night message (up to 60 seconds) DAY(3) - Answer greeting message (up to 30 seconds) DAY(5) - Pacifier message (up to 10 seconds)
Step 4.	Momentarily press the START switch and begin talking into the handset or press play on the tape player. A handset may be used to monitor.
Step 5.	When finished recording, momentarily press the START switch. Playback is automatic.
Step 6.	Record the remaining announcements by repeating steps 3-5 .
Step 7.	Place ACD-10 back into the answer mode when local recording is complete.

2. Remote

Step 1.	Enter programming as shown in section D above.
Step 2.	Enter * then 1, 2 or 3 to record the (1) "Pacifier", (2) "Greeting" or (3) "Night" announcement.
Step 3.	Wait for the tone, then begin recording.
Step 4.	Press "#" to stop recording. Playback is automatic.
Step 5.	Record the remaining announcements by repeating steps 2-4 .
Step 6.	Enter * then 4, 5 or 6 to review the (4) "Pacifier", (5) "Greeting" or (6) "Night" announcement again.

E. Quick Programming Guide

	Enter Digits	- then -	Memory Location
Security code (factory set to 845464)	6 digits	then	#47
Pacifier delay time in seconds (000-250, factory set to 60 seconds)	3 digits	then	#41
Break delay time in seconds (000-250, factory set to 15 seconds)	3 digits	then	#42
Hold alarm time, in minutes (00-99, factory set to 2 minutes)	2 digits	then	#43
Station ring limit (01-99, 00 disables, factory set to 10 rings)	2 digits	then	#44
Set all programming features to factory settings (including security code)	###		
Set statistics data output to tab delimited ASCII text format	**2		
Set statistics data output to space delimited ASCII text format	**3		
Set statistics data output to column format (factory setting)	**4		
Record pacifier on hold announcement	*1		
Record answer announcement	*2		
Record night announcement	*3		
Playback pacifier announcement	*4		
Playback answer announcement	*5		
Playback night announcement	*6		
Select standard DAY (5) (auto-answers after 5 rings)	*7		
Select standard DAY (3) (auto-answers after 3 rings)	*8		
Select NIGHT mode	*9		
Set the time and date	mmhhDDMMYY then		#40

Note: mm = Minutes, hh = Hours (24-hour), DD = Day, MM = Month, YY = Year

F. Pacifier Delay Time (factory set to 60 seconds)

The time in seconds a call waits on hold between hearing the pacifier announcement can be programmed from 1 second (enter 001) to 250 seconds (enter 250). Enter 000 to disable the pacifier message (see example below).

To Program the ACD-10...	Step 1 - See Programming section C	Step 2 - Enter Digits
...to a pacifier delay time of 90 seconds	Enter Programming	0 9 0 # 4 1
...to disable the pacifier message	Enter Programming	0 0 0 # 4 1

G. Break Delay Time (factory set to 15 seconds)

The time in seconds an agent has after completing a call to "catch their breath" and finish paper work before receiving another call. **Note:** Camped-on calls will ring in immediately without a break delay time.

To Program the ACD-10...	Step 1 - See Programming section C	Step 2 - Enter Digits
...to a break delay time of 30 seconds	Enter Programming	0 3 0 # 4 2
...to disable the break delay time	Enter Programming	0 0 0 # 4 2

H. Remote Mode Selection

When in programming, one of the three answer modes may be selected.

To Program the ACD-10...	Step 1 - See Programming section C	Step 2 - Enter Digits
...to be in the DAY(5) mode	Enter Programming	* 7
...to be in the DAY(3) mode	Enter Programming	* 8
...to be in the NIGHT mode	Enter Programming	* 9

I. Hold Alarm Time (factory set to 2 minutes)

The hold alarm time only needs to be set if the LM-24D Display Module is used for monitoring line and station activity. When a call is on hold for longer than the programmed hold alarm time, it will be displayed as a fast flashing line and the LM-24D will produce a warble tone. While in programming, enter 2 digits (representing the time in minutes) followed by #43.

To Program the ACD-10...	Step 1 - See Programming section C	Step 2 - Enter Digits
...to have a hold alarm time of 4 minutes	Enter Programming	04 # 4 3
...to disable the hold alarm time	Enter Programming	0 0 # 4 3

J. Station Ring Limit

If a station rings (inbound or transferred C.O. call) un-answered and the ring limit is met, the station will be marked "unavailable" and the call will be sent to another agent. Calls will no longer be sent to that station until it is manually made "available" again (see Operation section D). The station ring limit is factory set to 10 rings. While in the programming mode, enter 2 digits (number of rings) followed by #44.

To Program the ACD-10...	Step 1 - See Programming section C	Step 2 - Enter Digits
...to set the station ring limit to 8	Enter Programming	0 8 # 4 4
...to disable the station ring limit	Enter Programming	0 0 # 4 4

K. Time and Date

The time and date only need to be set if the serial RS-232 port is used to collect detailed call activity data. This allows each call record to be stamped with the proper time and date. When in programming follow the steps shown at the right.

To Program the Date and Time of the ACD-10...	Enter Digits:
Minutes (mm)	2 digits (00 - 59)
Hours (hh) Note: 24 hour clock.	2 digits (00 - 24)
Date (DD)	2 digits (01 - 31)
Month (MM)	2 digits (1 - 12)
Year (YY)	2 digits (01 - 99)
Enter string in the memory location...	mm hh DD MM YY # 4 0

Operation

A. Protocols

- ACD Protocol (Automatic Call Distributor)** - The **ACD-10** distributes inbound calls to the next available or longest idle agent so that agents are more likely to get a similar amount of “free” time between calls. Calls answered by the **ACD-10** will be indicated by a custom double ring cadence.
- UCD Protocol (Uniform Call Distributor)** - The **ACD-10** distributes inbound calls so that each agent receives approximately the same number of calls. Calls answered by the **ACD-10** will be indicated by a custom double ring cadence.
- Hunt Group Protocol** - The **ACD-10** distributes inbound calls so that Agent **#10** receives the most calls. Agent **#11** receives calls only if Agent **#10** is busy, and so on up the line so that Agent **#15** is least likely to receive an inbound call. Calls answered by the **ACD-10** will be indicated by a custom double ring cadence.
- Ring Group Protocol** - The **ACD-10** will ring all available agent's phones, the first agent to pick up, answers the call.

B. Day Mode (see DIP Switch Programming, section B)

In the **DAY(3)** or **DAY(5)** mode of operation, the **ACD-10** will send inbound calls to the agents based on the selected protocol (above). Agent's phones will ring in a standard cadence indicating a new call. If the call is not answered by an agent within three rings (**DAY(3)** mode) or five rings (**DAY(5)** mode), the **ACD-10** will answer the call, play the “Answer Greeting” announcement, then place the call on hold. The agent's phone will now ring in a double ring cadence indicating that the call is on hold. If call screening is selected (DIP switch 3 **ON**), all calls are answered and given the “Answer Greeting” announcement. Then the **ACD-10** will send the inbound calls to the agents based on the selected protocol. In the call screening mode, ring delay is changed to one ring for **DAY (3)** or two rings for **DAY (5)**.

While calls are on hold, a pacifier announcement will be played based on a timed interval (factory set to 60 seconds). If a station rings past the station ring limit (factory set to 10 rings) it is automatically marked as “unavailable” and the call is sent to another agent. No other calls will be sent to that agent, until it is manually made available again (see section **D** below).

C. Night Mode (see DIP Switch Programming, section B)

In the **NIGHT** mode, calls will be answered, given the “Night” announcement and dropped (DIP switch 4 **ON**). Alternatively, in the **NIGHT** mode, no calls are answered (DIP switch 4 **OFF**). There are three ways to put the **ACD-10** into the night mode: **1.** From remote programming **2.** From the front panel. **3.** By providing a hard contact closure (remote night switch) to the remote night mode screw terminals (back panel).

Note: The remote night mode switch has priority, so when it is used (contact closed), the **ACD-10** displays this as a blinking **NIGHT LED** and the **ACD-10** can only be removed from the night mode by opening the closure.

When the **NIGHT** mode is activated, calls connected to agents or camped-on to agents will remain, but calls waiting on hold for an available agent will be given the “Night” announcement and dropped.

D. Station Features

The **ACD-10** is designed to function as an efficient inbound call distributor. Many PABX type features are offered, but there is not the ability for multiple agents to access intercom dial tone at the same time. If a busy signal is given to an off-hook phone, intercom dial tone is not available. Hang up and try again a few seconds later.

- Station Unavailable** - To prevent incoming and transferred calls from ringing that phone:

Step 1	Step 2	Step 3
Go off-hook on the desired station	Enter “681”	Hang up

While a station is marked as unavailable, stutter dial tone is given to that phone. From power-up, all stations are automatically made unavailable, and do not appear on the optional **LM-24** display. Use the station available code (see below) to activate the required stations from power-up.

- Station Available** - To allow incoming and transferred calls to ring to that phone:

Step 1	Step 2	Step 3
Go off-hook on the desired station	Enter “682”	Hang up

- Directed Call Pick Up** - To pick up a particular agent's parked/ringing call (not available in Ring Group mode or camped-on calls):

Step 1	Step 2	Step 3
Go off-hook	Enter “#”	Enter agent's station number (10-15)

- Call Park** - To place a call on hold, and busy out your phone:

Step 1	Step 2	Step 3
Flash	Enter “50”	Hang up

Note: To pick up a call on the phone it was parked at, simply come back off-hook. To pick up a parked call from a different phone, use the “Directed Call Pickup” feature above.

- Paging** - To access the paging port:

Step 1	Step 2	Step 3
Go off-hook	Enter “56” and speak into the handset	Hang up

6. **Intercom** - To talk to another agent:

Step 1	Step 2	Step 3
Go off-hook	Enter agents station number (10-15)	Converse, then hang up

7. **Blind Transfer** - To transfer a call to another agent: *Note: If the station is busy, you may camp-on the call by hanging up.*

Step 1	Step 2	Step 3	Step 4
Flash	Enter agents station number (10-15)	Wait for ringback tones	Hang up

8. **Supervised Transfer** - To transfer a call to another agent:

Step 1	Step 2	Step 3	Step 4
Flash	Enter agents station number (10-15)	Wait for answer, converse	Hang up

Note: If the station dialed is busy, you may camp-on the call by hanging up. If after conversing with the agent, it is decided that the transfer is no longer required, simply ask the agent to hang up, and the call will be instantly reconnected.

9. **Conference** - To conference another agent into an established call:

Step 1	Step 2	Step 3	Step 4
Flash	Enter agents station number (10-15)	Wait for answer, converse	Flash again

10. **Outside Line** - To gain access to an outside line:

Step 1	Step 2	Step 3
Go off-hook	Enter "9" and wait for dial tone	Dial desired number

11. **Direct Trunk Access** - To directly access a specific trunk:

Step 1	Step 2	Step 3
Go off-hook	Enter "8"	Enter line number (01-10)

12. **Transfer Out of System** - To produce a flash on the outside line, allowing agents to use Centrex or PABX 3-way calling or transfer features external to the **ACD-10**:

Step 1	Step 2	Step 3	Step 4
Flash	Wait for dialtone	Enter *	Use external features

13. **Camp-On** - During a transfer if the station dialed is busy, you may camp-on the call by hanging up. If the station already has two camped on calls or has been made unavailable, the call will immediately ring back.

E. RS-232 Call Statistics Output

The **ACD-10** can output call statistics to a PC or serial printer through its RS-232 serial port. The **ACD-10** logs the date of call, time of call, line number of call, time the caller was on hold, agent that handled call, and type of call (see Call Type Codes below). The **ACD-10** features an internal clock/calendar that is used to date stamp each call record. After initial power-up, this internal clock must be set (see **Programming** section K to set time and date).

Simulated Call Statistics Output

DATE	TIME	LINE	ON-HOLD	AGENT	AGT TIME	CODE
09/07/01	10:22:16 AM	01	00:00:07	10	00:00:14	COMPL
09/07/01	10:23:58 AM	01	00:00:22			ABAND
09/07/01	10:24:45 AM	01	00:00:11	10	00:00:09	TRANS
09/07/01	10:26:05 AM	01		11	00:01:17	COMPL
09/07/01	10:27:01 AM	02		11	00:00:41	OUT

Call Type Codes

Code	Description
COMPL	Completed Call
ABAND	Abandoned Call
TRANS	Transferred Call
OUT	Outbound Call

1. Call Type Codes

a. Completed Call

This call type represents the normal procedure for call distribution in which an incoming call is assigned to an agent, the agent and caller converse, and the call ends when both caller and agent hang up. Notice that in the example call records above, the second to last call record has no on-hold time listed. This indicates that the agent picked up the call before the **ACD-10** answered (before the ring delay had been met) so that no hold time was accumulated.

b. Abandoned Call

An abandoned call record is generated when a caller on hold in the **ACD-10** system hangs up before an agent can get to the call. This statistic is particularly useful in determining staffing needs; a relatively large number of abandoned calls would indicate that there are not enough agents to handle incoming calls in a timely fashion.

c. Transferred Call

This call type is produced when a call is transferred from one agent to another. The time that the caller has been on hold and the time the first agent spent on the call are logged in this call record. Note that it is possible to determine which agent the call was transferred to by looking for the next appearance of the same line number in subsequent call records. One or more lines down in the call records the line number appears again, with the **ON HOLD** column blank, the new agent number indicated and the call type logged as **COMPL**. In this way it is possible to trace a transferred call from start to finish.

d. Outbound Call

With this call type the **ACD-10** logs the time and line number of outbound calls made by agents.

2. PC Operation and Configuration

Important: Viking Electronics will NOT support computer software or hardware problems. If you experience these problems, research your hardware and/or software instruction manuals or contact the manufacturer's technical support department.

Start your communication software. "Hyperterminal" is the communication software supplied with all Windows 32-bit operating systems. Configure a profile called "ACD-10" as shown to the right.

Save your settings. This will allow you to retrieve your settings whenever you wish to download the ACD-10 data without having to manually set the parameters each time.

Connect your PC to the serial port of the ACD-10. From the PC, start the communications software and open the profile you created. Call records will appear as they are sent via the serial port by the ACD-10. Note that it is possible to minimize your communications software application so the PC can perform other functions while calls are being logged in the background.

Communication Software Configuration	
Com	That of your serial port (1-4)
Baud Rate	9600
Data Bits	8
Stop Bits	1
Parity	none
Flow Control	Hardware

3. Printer Operation and Configuration

Important: Viking Electronics will NOT support computer software or hardware problems. If you experience these problems, research your hardware and/or software instruction manuals or contact the manufacturer's technical support department.

Connect your serial printer to the RS-232 port of the ACD-10 and configure your printer as shown to the right.

Serial Printer Configuration	
Baud Rate	9600
Data Bits	8
Stop Bits	1
Parity	none
Flow Control	Hardware

4. Output Formats

a. Tab Delimited ASCII Text Format (enter **2 while in Programming)

This format is used when call records are to be stored and processed using spreadsheet or database software. The ACD-10 sends the call records to the serial port of a PC with the data fields delimited by ASCII tab characters, where they are stored temporarily by communications software such as HyperTerminal. The user then periodically retrieves the call records and imports them into existing spreadsheet or database files for storage or processing.

b. Space Delimited ASCII Text Format (enter **3 while in Programming)

This format is used if it is preferred or necessary for the ACD-10 to send call records with the data fields delimited by ASCII space characters rather than tabs.

c. Column Text Format (enter **4 while in Programming)

This format is best for use with a printer or PC set up to print or display the call records to the screen as they are generated.

Options

A. ACD-10-EB Expansion Board

The ACD-10 is expandable from 6 to 10 stations with the optional ACD-10-EB. In addition to gaining 4 more stations, there is also the option to add the "Transfer Only" station feature available on stations 16, 17, 18 and/or 19 by installing the included ACD10 V1.4 chip. Follow the instructions below to install the ACD-10-EB and the ACD10 V1.4 chip.

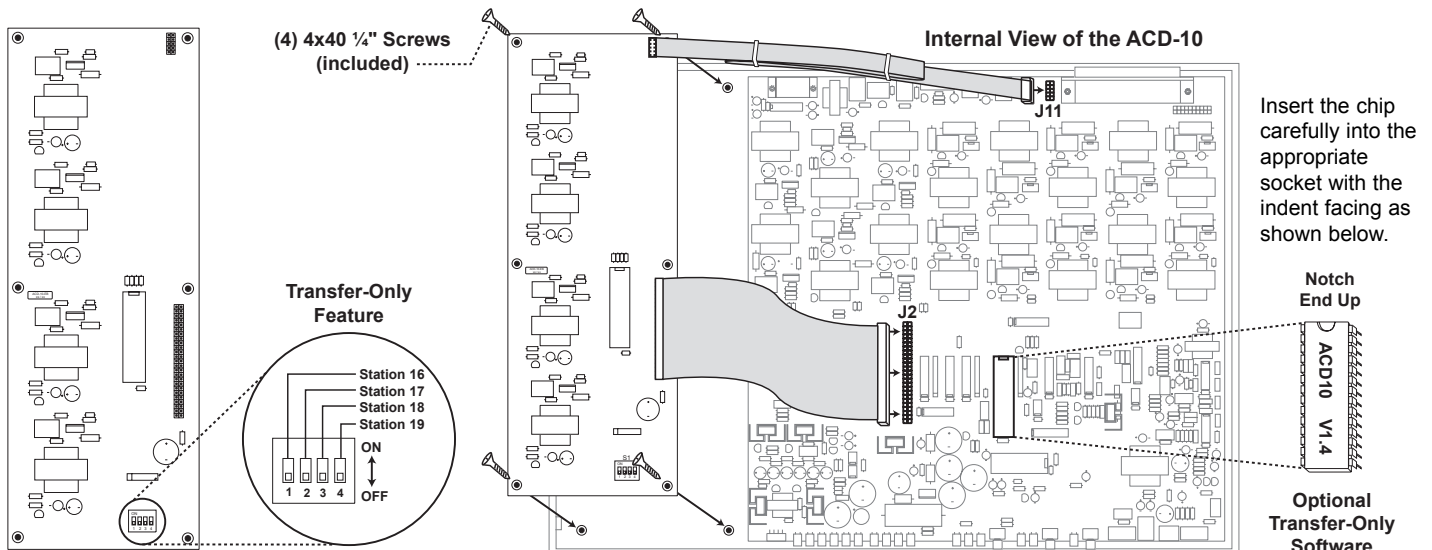

Important: Electronic components are sensitive to static electricity. Personnel and the work area should be grounded before handling.

1. Installation

Step 1.	Power down the ACD-10 .
Step 2.	Remove the ACD-10 cover using the supplied 3/32" hex key.
Step 3.	Replace existing software chip with the ACD10 V1.4 chip if the "Transfer Only" feature is needed as shown on the previous page.
Step 4.	Snap the ACD-10-EB into place as shown in the diagram on the previous page.
Step 5.	Secure the ACD-10-EB board with the supplied 4 x 40 1/4" screws.
Step 6.	Carefully plug the two ribbon cable connectors into the J2 and J11 pins as shown in the diagram on the previous page.
Step 7.	Set DIP switches to ON to activate "Transfer Only" station feature if needed.
Step 8.	Replace the cover on the ACD-10 and power the unit on.

2. Station Activation

To Activate Stations 16 - 19...	
Step 1.	Come off-hook on the station you wish to activate.
Step 2.	Dial "682" and hang up.
Step 3.	Repeat steps 1 and 2 for each station you wish to activate.

3. Programming

Programming of the **ACD-10** remains unchanged with the addition of the **ACD-10-EB** except for the "Transfer Only" feature switches available on the **ACD-10-EB** board when the **ACD10 V1.4** software chip is installed. Turn the switch **ON** to activate the "Transfer Only" feature for the associated station as shown in the diagram on the previous page.

4. Operation

The addition of the **ACD-10-EB** board allows the **ACD-10** to be expanded from 6 to 10 stations, bringing into service stations 16, 17, 18 and 19. Normal operation of the **ACD-10** remains unchanged. If the "Transfer Only" switch is **ON** and the **ACD10 V1.4** chip is installed, the associated station (when activated) allows only transferred calls to ring through. These can be in the form of blind transfers, supervised transfers, intercom calls, conference calls and camp-on call transfers. Since having the switch **ON** prevents incoming calls from ringing through, that station can be used as a tie-line to transfer calls to another phone system, or be used by manager, billing agents or any other personnel that should not get inbound calls, but is available to receive calls transferred from any agent. **Note:** The "Transfer Only" station feature is not available in the ring group protocol.

B. Optional LM-24D Display

The **LM-24D** will display the mode in which the **ACD-10** is operating in. Also, ringing lines or lines on hold waiting for an agent appear as a fast flashing lamp. Calls on hold longer than the programmable hold alarm time will flash and warble. Once a call is answered by an agent, it will appear as a solid line lamp.

Stations never put into service (made available) from system power-up will stay dark. Stations that are in-use or ringing are displayed as a solid lamp. Stations made unavailable will appear as a lamp that winks off every few seconds. **Note:** See the diagram at the right for display layout.

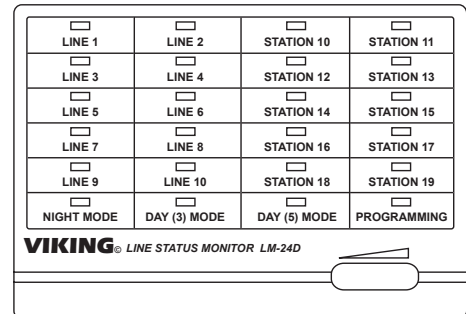

Our Technical Support Department is available for assistance Monday 8am - 4pm and Tuesday to Thursday 8am - 5pm central time. So that we can give you better service, before you call please:

1. Know the model number, the serial number and what software version you have (see serial label).
2. Have your Technical Practice in front of you.
3. It is best if you are on site.

RETURNING PRODUCT FOR REPAIR

The following procedure is for equipment that needs repair:

1. Customer must contact Viking's Technical Support Department at 715-386-8666 to obtain a Return Authorization (RA) number. The customer MUST have a complete description of the problem, with all pertinent information regarding the defect, such as options set, conditions, symptoms, methods to duplicate problem, frequency of failure, etc.
2. Packing: Return equipment in original box or in proper packing so that damage will not occur while in transit. Static sensitive equipment such as a circuit board should be in an anti-static bag, sandwiched between foam and individually boxed. All equipment should be wrapped to avoid packing material lodging in or sticking to the equipment. Include ALL parts of the equipment. C.O.D. or freight collect shipments cannot be accepted. Ship cartons prepaid to: Viking Electronics, 1531 Industrial Street, Hudson, WI 54016
3. Return shipping address: Be sure to include your return shipping address inside the box. We cannot ship to a PO Box.
4. RA number on carton: In large printing, write the R.A. number on the outside of each carton being returned.

RETURNING PRODUCT FOR EXCHANGE

The following procedure is for equipment that has failed out-of-box (within 10 days of purchase):

1. Customer must contact Viking's Technical Support at 715-386-8666 to determine possible causes for the problem. The customer MUST be able to step through recommended tests for diagnosis.
2. If the Technical Support Product Specialist determines that the equipment is defective based on the customer's input and troubleshooting, a Return Authorization (R.A.) number will be issued. This number is valid for fourteen (14) calendar days from the date of issue.
3. After obtaining the R.A. number, return the approved equipment to your distributor, referencing the R.A. number. Your distributor will then replace the product over the counter at no charge. The distributor will then return the product to Viking using the same R.A. number.
4. The distributor will NOT exchange this product without first obtaining the R.A. number from you. If you haven't followed the steps listed in 1, 2 and 3, be aware that you will have to pay a restocking charge.

WARRANTY

Viking warrants its products to be free from defects in the workmanship or materials, under normal use and service, for a period of one year from the date of purchase from any authorized Viking distributor or 18 months from the date manufactured, whichever ever is greater. If at any time during the warranty period, the product is deemed defective or malfunctions, return the product to Viking Electronics, Inc., 1531 Industrial Street, Hudson, WI, 54016. Customer must contact Viking's Technical Support Department at 715-386-8666 to obtain a Return Authorization (R.A.) number.

This warranty does not cover any damage to the product due to lightning, over voltage, under voltage, accident, misuse, abuse, negligence or any damage caused by use of the product by the purchaser or others.

Viking's sole responsibility shall be to repair or replace (at Viking's option) the material within the terms stated above. VIKING SHALL NOT BE LIABLE FOR ANY LOSS OR DAMAGE OF ANY KIND INCLUDING INCIDENTAL OR CONSEQUENTIAL DAMAGES RESULTING DIRECTLY OR INDIRECTLY FROM ANY BREACH OF ANY WARRANTY EXPRESSED OR IMPLIED, OR FOR ANY OTHER FAILURE OF THIS PRODUCT. Some states do not allow the exclusion or limitation of incidental or consequential damages, so this limitation may not apply to you.

THIS WARRANTY IS IN LIEU OF ALL OTHER WARRANTIES, EXPRESSED OR IMPLIED, INCLUDING THE WARRANTIES OF MERCHANTABILITY AND FITNESS FOR A PARTICULAR PURPOSE, WHICH ARE HEREBY EXCLUDED BEYOND THE ONE YEAR DURATION OF THIS WARRANTY. Some states do not allow limitation on how long an implied warranty lasts, so the above limitation may not apply to you.

Due to the dynamic nature of the product design, the information contained in this document is subject to change without notice. Viking Electronics, and its affiliates and/or subsidiaries assume no responsibility for errors and omissions contained in this information. Revisions of this document or new editions of it may be issued to incorporate such changes.