

## V-9940

# EXPANDABLE STATION LEVEL PAGE ADAPTER

### INTRODUCTION

The V-9940 is an Expandable Station Level Page Adapter designed to provide ring trip and page access circuitry for use on standard device telephone lines. These instructions contain the specifications and information necessary to install, operate and maintain the V-9940 Expandable Station Level Page Adapter.

**IMPORTANT: Please review dip switch settings (page 3) for equipment suitability.**

### FCC Information

When installing the V-9940, contact the local Telephone Company and give them the following information:

- The telephone number of the line to which the V-9940 will connect;
- The FCC Registration #: BAF9I7-13957-OT-N;
- The ringer equivalence number: 1.1A

If the V-9940 is disconnected from its present line, contact the local Telephone Company to make them aware of the change.

Telephone Company Procedures: the goal of the telephone company is to provide the best service possible. In order to do this, it may occasionally be necessary for them to make changes in their equipment, operations or procedures. If these changes potentially affect the service or the operation of customer equipment, the Telephone Company will give written notice to allow any changes necessary to maintain uninterrupted service.

### SPECIFICATIONS

#### Access Methods

- Centrex numbers
- Loop start and ground start central office lines
- PABX station numbers

Figure 1 depicts a block diagram of a typical PABX installation.



### Features

- Ring trip on first ring
- 600 Ohms output; 8 Ohms output with AGC
- Multiple units may be used for multi-zone paging with all call behind a PABX
- Use with Valcom multi-zone page control unit for multi-zone paging Centrex or C. O. lines (DTMF signaling only)
- Use with Valcom handsfree page units for talkback paging
- Background music input
- Open loop detect reset
- Audio sensing circuit for reset
- Time out reset
- Manual reset
- Answer verification tone
- All call override tone
- Battery reversal indicator
- Auxiliary Make/Break contact
- Built in 66 type connection block
- Complies with UL 145



If the PABX **IMMEDIATELY** returns any type of tones to the called party (dial tone, reorder tone, etc.) then **STATION LEVEL PAGING CAN NOT BE USED**. Consult the Valcom catalog for an appropriate trunk level page adapter. If there is silence of at least **10 SECONDS** before any tones are returned, then one-way paging may be used. If the line **REMAINS SILENT** for at least 1 and 1/2 minutes after disconnect, then one-way or talkback paging may be used.

If the type of paging desired is possible on a station level of the PABX, continue in this section to determine equipment required.

- **One Zone of One-Way Paging:**

This arrangement requires one PABX station number, one V-9940 page adapter, appropriate Valcom One-Way Amplified Speaker Assemblies and a -24VDC power supply.

- **Multi-Zone One-Way Paging with All Call:**

This arrangement requires a PABX station number and V-9940 for each zone and an additional number and V-9940 for all call. One-Way amplified Speaker Assemblies and -24VDC power supplies are also required.

- **One Zone of Talkback Paging:**

This arrangement requires one V-9940, one V-9941A, one-zone talkback unit, appropriate 45 Ohm talkback speakers (maximum 2), and a VP-624B power supply. See Note.

### **Centrex or C. O. Line Access to Paging:**

**NOTE: Although the V-9940 will work on both loop start or ground start lines, when using Centrex service, ground start lines provide better security against returned tones. In addition, Centrex lines should be optioned for cut OFF when disconnect occurs.**

- **One Zone of One-Way Paging:**

One zone of One-Way Paging requires one Centrex or C. O. Line, a V-9940, One-Way Amplified Speaker Assemblies and a -24VDC power supply.

- **Multi-Zone One-Way Paging:**

Multi-zone One-Way Paging requires one Centrex or C. O. Line, a dial select page control unit (V-2003A, V-2006A, V-1109RTVA, V-119RTVA or V-136RTHF), appropriate One-Way Amplified Speaker Assemblies and a -24VDC power supply.

**NOTE: All Call is included with the V-2003A, V-2006A and the V-1109RTVA.**

It may be added to the V-119RTVA with a V-1118 and to the V-136RTHF with a V-1134. See Note.

- **One Zone of Talkback Paging:**

One Zone of Talkback Paging requires one Centrex or C. O. Line, one V-9940, one V-9941A, one zone talkback unit, 45 Ohm talkback speakers (maximum 2) and a VP-624B power supply. See Note.

- **Multi-Zone Talkback Paging:**

Multi-Zone Talkback Paging requires one Centrex or C. O. Line, one V-9940, a dial select page control unit (V-2003AHF, V-2006AHF, V-1109RTHF, V-119RTHF or V-136RTHF), appropriate talkback speakers and a -24VDC power supply.

**NOTE: One-way All Call is included with the V-2003AHF, V-2006AHF, and V-1109RTHF. It may be added to the V-119RTHF with a V-1118 and to the V-136RTHF with a V-1134. See Note.**

Wiring of each arrangement is covered in the Installation Section.

**NOTE: When using the V-9940 Expandable Station Level Paging Adapter to access multi-zone or handsfree control units, it should be understood that the quality and noise characteristics of the C. O. Line circuit may affect the operation of this equipment adversely.**

### **Dip Switch Settings**

The dip switch settings are crucial to proper operation of the V-9940 and are different for each application. The dip switches select the way the V-9940 releases from the line and how long a page may be made. There are three ways the V-9940 releases from the line that are dependent on dip switch settings:

### **Open Loop Detect**

The V-9940 detects a 150ms or longer break in loop current one second after ring trip and release from the line. The one second delay in line supervision is allowed due to the instability of some C. O. and Centrex lines for the first second after ring trip.

Dip switch settings: Set dip switches 1 and 8 "ON", dip switches 2 through 7 "OFF".

**NOTE:** This setting provides unlimited page length. In certain instances a default timeout release is recommended. To select a default timeout, turn one of dip switches 2 through 7 "ON". Refer to Figure 4 for the maximum page length each dip switch allows.

### Time Out Release

The V-9940 will release from the line a pre-determined amount of time after ring trip as determined by dip switch settings.

Typical Applications: Access from a PABX Station to one zone of talkback page (station level access not normally used with talkback).

Dip Switch Settings: Set dip switches 1 and 8 "ON". Set one of dip switches 2 through 7 "ON" to select the maximum page length.

**NOTE:** This setting assigns a limited page length. See PABX Station level Paging to determine if the PABX is compatible for station level page.

### Audio Sense Release

The V-9940 will release from the line after a pre-determined amount of time that silence is detected as determined by dip switch settings.

Typical Applications: Access from a PABX Station to one zone of one-way page or multiple zones of one-way page using multiple PABX stations and multiple V-9940s.

Dip switch settings: Set dip switch 1 "OFF", dip switch 8 "ON". Set one of dip switches 2 through 7 "ON" to select the length of time the unit stays active after last sensing audio. (Normally dip switch 6 or 7 - for 8 or 4 seconds).

**NOTE:** This setting provides unlimited page length. See PABX Station Level Paging to determine if the PABX is compatible for station level page. When used with talkback paging, the talkback audio may delay or cancel the audio sense release.

In some special applications, a manual reset can be used to provide release from the line by providing a momentary ground to the manual reset pin of the V-9940.

## INSTALLATION

### Regulatory Information

This equipment is to be installed only in restricted access areas (dedicated equipment rooms, equipment closets or the like) in accordance with Articles 110-16, 110-17, and 110-18 of the National Electrical Code, ANSI/NFPA No. 70.

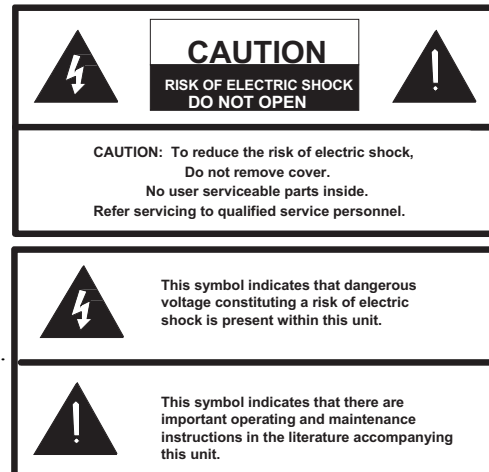

When using this equipment, basic safety precautions should always be followed to reduce the risk of fire, electric shock and injury to persons including the following:

1. Never install telephone wiring during a lightning storm.
2. Never install telephone jacks in wet locations unless the jack is specifically designed for wet locations.
3. Never touch uninsulated telephone wires or terminals unless the telephone line has been disconnected at the network interface.
4. Use caution when installing or modifying telephone lines.

### General

The following sections contain step-by-step instructions for wiring the V-9940 and associated Valcom equipment. If the results of a test do not correspond with what is shown, DO NOT PROCEED UNTIL THE PROBLEM HAS BEEN CORRECTED.

During installation, Figure 2 may be referred to for location and numbering of punchdown block. Refer to Figure 3 for punchdown block pinouts and Figure 4 for dip switch settings.

**NOTE:** To aid system testing and balancing, be sure to set the individual volume controls at approximately ½ volume when installing one-way amplified speaker assemblies.

## Mounting

Remove the metal mounting plate from the rear of the V-9940 enclosure. Using two #6 3/4 inch wood screws, mount the plate in a vacant space on the backboard with the telephone system common equipment. **Both mounting holes must be utilized to insure secure mounting of the unit.** Provisions for mounting to a single or double gang junction box are provided. See Figure 5.

Open the V-9940 enclosure to allow access to connections and option switches. Slide the rear of the unit (contains the board) onto the mounting plate. Lock enclosure to mounting plate with screw provided. Make connections. Replace cover and lock in place with #6 1/2 inch screws provided.

## Power Connections

**NOTE: Power is required for each V-9940 being used. If multiple units are used, power for additional units may be multiplied from pins 14 and 15 of a previous unit (pin 14 is "+" and pin 15 is "-").**

- Unplug power supply.
- Connect -24VDC "B" battery (may be referred to as "-" or "signal battery") from power supply to pin 30 on V-9940 and "B" ground "+" or "signal" ground) from power supply to pin 29.
- Connect -24VDC Ground from power supply to telephone system Ground.

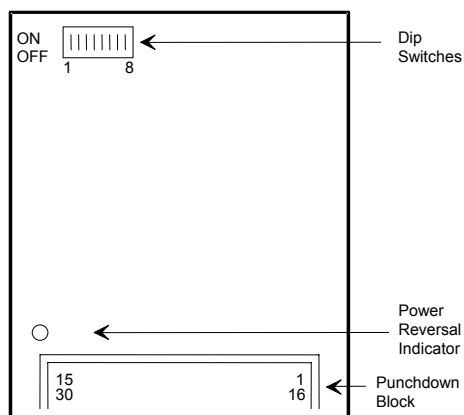

**FIGURE 2**  
LOCATION AND NUMBERING OF  
PUNCHDOWN BLOCK AND DIP SWITCHES

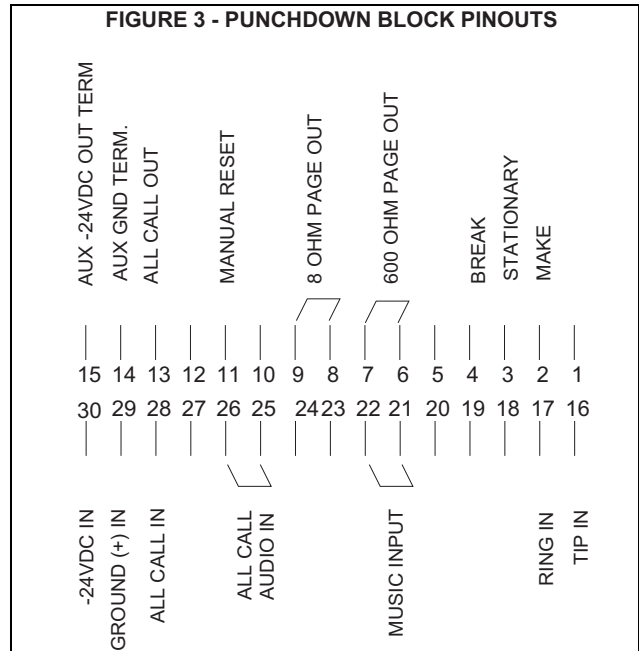

**Figure 4 Dip Switch Settings**

SW	OFF	ON
1	Audio Sense Enable	Time Out Enable
2	Not 1 Sec.	1 Second
3	Not 64 Sec.	64 Seconds
4	Not 32 Sec.	32 Seconds
5	Not 16 Sec.	16 Seconds
6	Not 8 Sec.	8 Seconds
7	Not 4 Sec.	4 Seconds
8	Loop Detect Disable	Loop Detect Enable

ON OFF

1 2 3 4 5 6 7 8

- Power Test:
  - a. Plug in power supply.
  - b. If power reversal LED is lit:
    1. Unplug power supply.
    2. Reverse connections on pins 29, 30.
    3. Repeat step 5.
- Unplug power supply.

**PABX Connecting Arrangements:**  
**NOTE: From the list below, determine the arrangement being used and proceed to the Figure indicated for step-by-step instructions.**

- One Zone of One-Way Paging: Go to Figure 6.
- Multi-Zone One-Way Paging with All Call (Multiple Talkpaths): Go to Figure 7.
- One Zone of Handsfree Paging: Go to Figure 8.

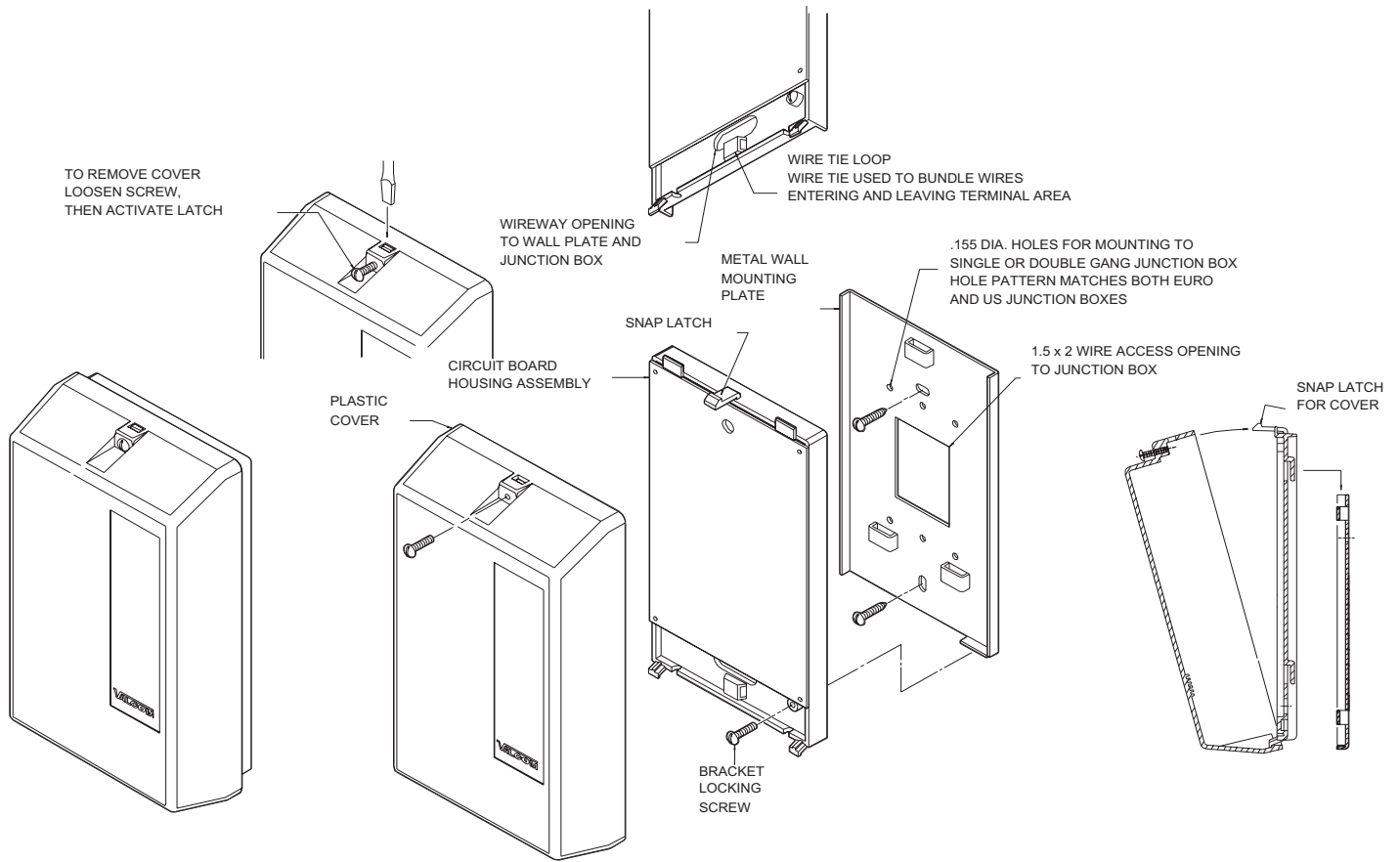
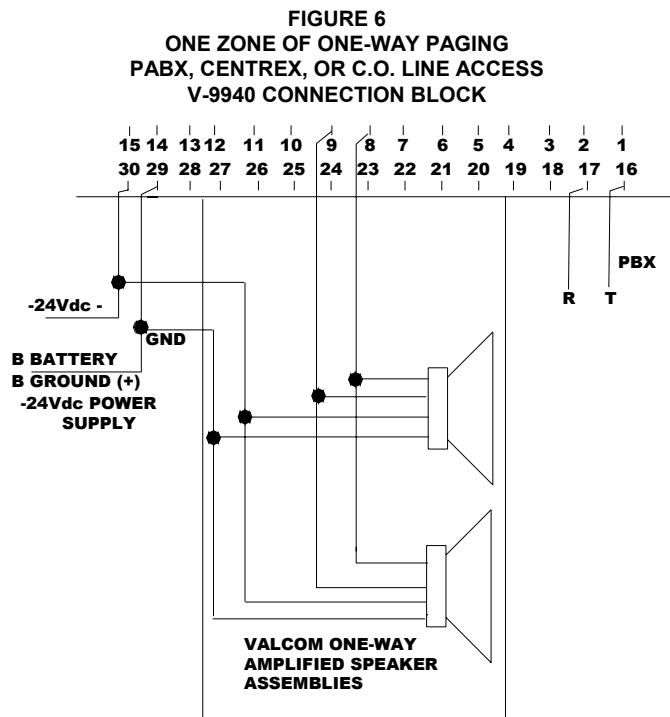

**FIGURE 5  
MOUNTING  
EXPLODED VIEW**

## Centrex or C. O. Connecting Arrangements

From the list below, determine the arrangement being used and proceed to the Figure indicated for instructions.

- One Zone of One-Way Paging: Go to Figure 5.
- Multi-Zone One-Way Paging will All Call (Multiple Talkpaths): Go to Figure 6.
- Multi-Zone One-Way Paging (1 Talkpath): Go to Figure 8.
- One Zone Talkback Paging: Go to Figure 7.
- Multi-Zone Talkback Paging: Go to Figure 8.



## WIRING INSTRUCTIONS

Place a check by each step as it is completed.

- \_\_\_ 1. Connect Tip of the PABX, Centrex or C. O. Line to pin 16 and Ring to Pin 17 of the V-9940.
- \_\_\_ 2. Connect Tip of the Valcom one-way amplified speaker assemblies being used to the V-9940 pin 8 and Ring to pin 9.
- \_\_\_ 3. Connect the Ground Lead from the speaker assemblies to the power supply "B" Ground (or "+").
- \_\_\_ 4. Connect the -24VDC lead from the speaker assemblies to the power supply "B" Battery (or "-").
- \_\_\_ 5. Connect the output of a low level music source (optional) to pins 21 and 22.
- \_\_\_ 6. Dip Switch Settings:  
PABX: Switch 1 must be "OFF". Turn "ON" one of switches 2 to 7 to select the length of time the unit stays active after last sensing audio (reset timing). **SWITCH 8 MUST BE "ON".**  
Centrex or C. O. Line: Set Switches 1 and 8 "ON" and 2 through 7 "OFF". See section titled "Dip Switch Settings" for additional information regarding dip switched.
- \_\_\_ 7. When connections are complete replace cover and lock in place using the #6 ½ inch screws provided. Plug in power supply.

**FIGURE 7**  
**MULTI -ZONE ONE -WAY PAGING WITH**  
**ALL CALL (MULTIPLE TALKBACK)**  
**PABX, CENTREX, OR C.O. LINE ACCESS**

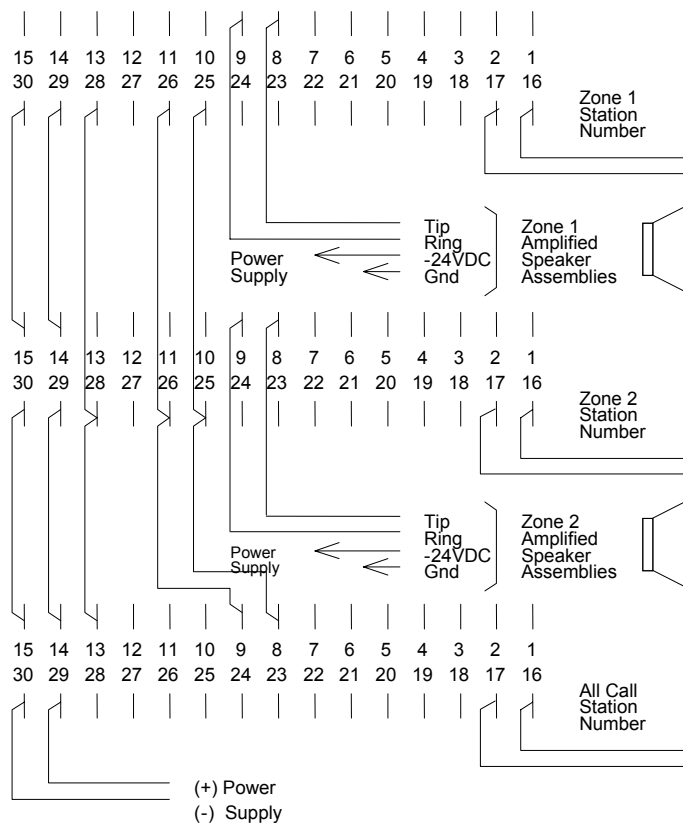

## WIRING INSTRUCTIONS

Place a check by each step as it is completed.

- \_\_\_ 1a. Connect Tip of the PABX station number for zone one to pin 16 and Ring to pin 17 of the V-9940 being used for zone one.
- \_\_\_ 1b. Connect Tip of the amplified speaker assemblies for zone one to pin 8 and Ring to pin 9 of the V-9940.
- \_\_\_ 1c. Connect the Ground lead of the speaker assemblies to the power supply Ground.
- \_\_\_ 1d. Connect the -24VDC lead of the speaker assemblies to the power supply -24VDC ("B" Battery or "-").
- \_\_\_ 2. Repeat Step 1 for each zone. REMEMBER, each zone requires its own station number and V-9940.
- \_\_\_ 3. All Call Connections:
  - \_\_\_ 3a. Connect Tip of the All Call station number to pin 16 and Ring to pin 17 of the V-9940.
  - \_\_\_ 3b. Strap from pin 9 of the all call V-9940 to pin 26 of each of the V-9940s being used for individual zones.
  - \_\_\_ 3c. Strap from pin 13 of the all call V-9940 to pin 28 of each of the V-9940s being used for individual zones.
- \_\_\_ 4. Music Input: Background music may be provided on a per zone basis. Connect a low level source to pins 21 and 22 of each V-9940 to receive music.
- \_\_\_ 5. Dip Switch Settings: Switch settings are the same for the individual zones and the all call.
  - \_\_\_ 5a. PABX - Switch 1 must be "OFF". Turn "ON" one of switches 2 to 7 to select the reset timing (the length of time the unit stays active after last sensing audio). Turn switch 8 "ON".
  - \_\_\_ 5b. Centrex or C. O. Line - Set switches 1 and 8 "ON", 2 to 7 "OFF". See Section titled "Dip Switch Settings" for additional information regarding dip switches.
- \_\_\_ 6. Adjust volume at individual speakers.
- \_\_\_ 7. When connections are complete, replace cover and lock in place using the #6 ½ inch screws provided. Plug in power supply.

## WIRING INSTRUCTIONS

Place a check by each step as it is completed.

- \_\_\_ 1. Connect Tip of the PABX Station, Centrex or C. O. Line to pin 16 of the V-9940.
- \_\_\_ 2. Connect Ring of the line to pin 17.
- \_\_\_ 3. Crossconnect pin 6 of the V-9940 to pin 1 of the V-9941A.
- \_\_\_ 4. Crossconnect pin 7 of the V-9940 to pin 2 of the V-9941A.
- \_\_\_ 5. Connect 45 Ohm talkback speakers (maximum 2) to pins 6 and 7 of the V-9941A.
- \_\_\_ 6. V-9941A Power Connections:
  - \_\_\_ 6a. Connect -24VDC Ground (+) to pin 3 of the V-9941A.
  - \_\_\_ 6b. Connect -24VDC Battery (-) to pin 4 of the V-9941A.
- \_\_\_ 7. Dip Switch Settings:
  - \_\_\_ 7a. PABX Access: Set switches 1 and 8 "ON". Turn "ON" one of switches 2 to 7 to select the maximum page length.
  - \_\_\_ 7b. Centrex or C. O. Line access: Set switches 1 and 8 "ON". Set switches 2 through 7 all OFF". See section titled "Dip Switch Settings" for additional information regarding dip switches.
- \_\_\_ 8. Refer to the V-9941A installation instructions for proper volume procedure.
- \_\_\_ 9. When all connections are complete, replace cover and lock in place using the #6 ½ inch screws provided. Plug in power supply.

**FIGURE 8**  
**ONE ZONE OF HANDSFREE PAGING**  
**PABX, CENTREX, OR C. O. LINE ACCESS**  
**V-9940 PUNCHDOWN BLOCK**

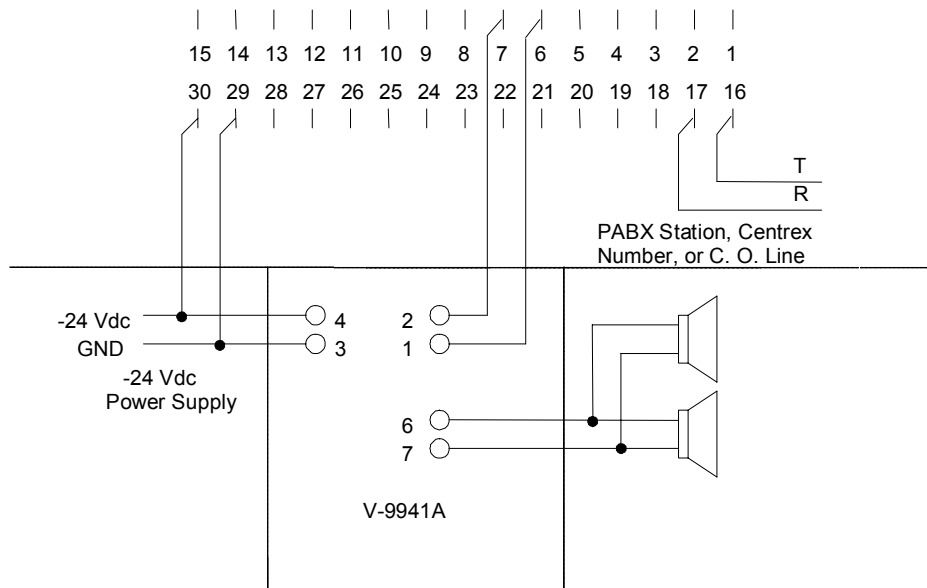

## WIRING INSTRUCTIONS

Place a check by each step as it is completed.

- \_\_\_ 1. Connect Tip of the Centrex or C. O. Line to pin 16 of the V-9940.
- \_\_\_ 2. Connect Ring of the line to pin 17.
- \_\_\_ 3. Crossconnect pin 6 of the V-9940 to the Tip "WHITE/BLUE" of a Valcom multi-zone dial select page control unit (such as the V-1109RTVA or V-1109RTHF).
- \_\_\_ 4. Crossconnect pin 7 of the V-9940 to the control unit Ring "BLUE/WHITE".
- \_\_\_ 5. Refer to the Installation Manual supplied with the control unit for speaker and power connections.
- \_\_\_ 6. Refer to the Installation Manual supplied with the control unit for proper volume adjustment procedures.
- \_\_\_ 7. Dip Switch Settings: Set dip switches 1 and 8 "ON". Set switches 2 to 7 all "OFF". See Section titled "Dip Switch Settings" for additional information regarding dip switches.
- \_\_\_ 8. When all connections are complete, replace cover and lock in place using the #6 ½ inch screws provided. Plug in power supply.

**FIGURE 9**  
**MULTI-ZONE ONE WAY OR HANDSFREE PAGING**  
**CENTREX OR C. O. LINE ACCESS**  
**V-9940 PUNCHDOWN BLOCK**

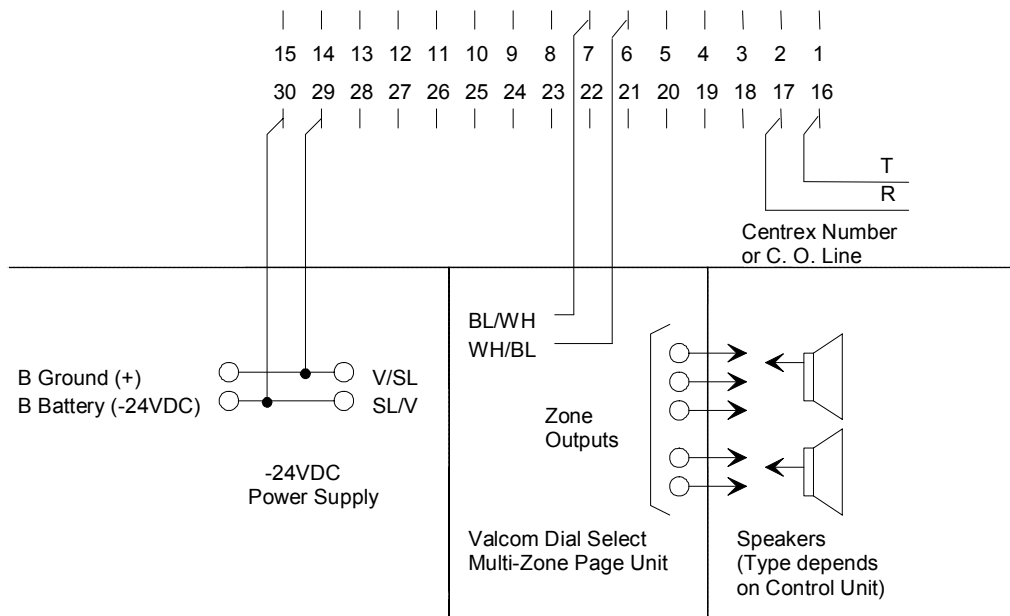

## OPERATION

### Circuit Description

The V-9940, Station Level Page Adapter, has three inputs: Tip and Ring from the line, music and all call; and two outputs: 8 Ohm and 600 Ohm.

Any input will provide audio at both the 8 Ohm and 600 Ohm outputs. Signals coming from the 8 Ohm output will be maintained 7dB below the level of the paging (this is not user adjustable). There is no modification of page or music signals when using the 600 Ohm output. The 600 Ohm output also provides a loop on access and may be used with loop start paging equipment.

In the idle state, signals from the music input will appear on both the 8 Ohm and 600 Ohm outputs. On receipt of superimposed ring generator on Tip and Ring, the V-9940 will be activated and will place a loop across the station Tip and Ring for ring trip. An answer verification tone will then be returned to the calling party and Tip and Ring audio will be connected to the 8 Ohm and 600 Ohm outputs.

After access, the reset circuitry is turned on. If the unit is set for loop detect, it will ignore any open loop conditions for the first second, then it will release when it senses an open loop on Tip and Ring lasting at least 150ms. If you are using the audio sense reset, the unit will stay on line until sensing a lack of audio (-22dB or less) for the period set by the dip switches. If using the time out reset, the unit will stay on the line for the preset length of time and then will reset, whether the page is complete or not. Upon release, the music source is reconnected to the outputs.

All call, if connected, will override both the music and page inputs. All call requires an additional station port for access and must be wired as shown in Figure 6. When the all call station number is dialed, any paging in progress will be overridden and an alert tone will be returned to the overridden parties. If they remain on line, on completion of the all call page, they will be reconnected to their respective zones and all timers will be reset, allowing a full page again on each zone.

### TECHNICAL ASSISTANCE

When trouble is reported, verify that power is being supplied to the unit and there are no broken connections. Check voltages for proper polarity on the crossconnect block. Table 1 identifies symptoms of possible problems with solutions. If a spare unit is available, continue to troubleshoot by substituting the spare unit for the suspected defective unit.

Assistance in troubleshooting is available from the factory. When calling, you should have a VOM, several clip leads, a telephone test set available and call from the job site. Call (540) 563-2000 or visit our website at <http://www.valcom.com>.

The V-9940 is not field repairable. Valcom, Inc. maintains service facilities in Roanoke, VA. Should repairs be necessary, attach the company name, address, phone number, contact person and the nature of the problem. Send the unit to:

**Valcom, Inc.**  
**Repair and Return Dept.**  
**5614 Hollins Road**  
**Roanoke, VA 24019-5056**

### SIMPLIFIED SCHEMATIC

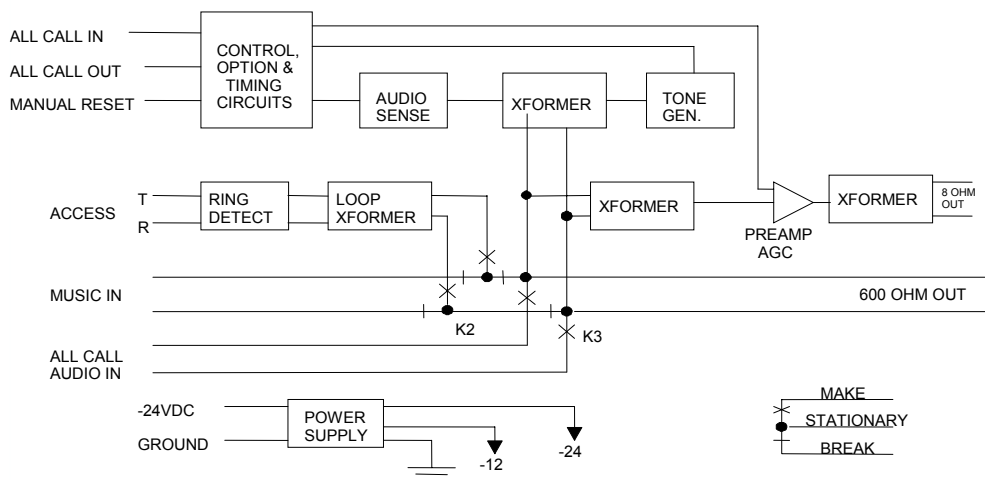

### VALCOM LIMITED WARRANTY

Valcom, Inc. warrants its products to be free from defects in materials and workmanship under conditions of normal use and service for a period of one year from the date of shipment. The obligation under this warranty shall be limited to the replacement, repair or refund of any such defective device within the warranty period, provided that:

1. inspection by Valcom, Inc. indicates the validity of the claim;
2. the defect is not the result of damage, misuse or negligence after the original shipment;
3. the product has not been altered in any way or repaired by others and that factory sealed units are unopened (a service charge plus parts and labor will be applied to units defaced or physically damaged);
4. freight charges for the return of products to Valcom are prepaid;
5. all units 'out of warranty' are subject to a service charge. The service charge will cover minor repairs (major repairs will be subject to additional charges for parts and labor).

**This warranty is in lieu of and excludes all other warranties, expressed or implied and in no event shall Valcom, Inc. be liable for any anticipated profits, consequential damages, loss of time or other losses incurred by the buyer in connection with the purchase, operation or use of the product.**

This warranty specifically excludes damage incurred in shipment. In the event a product is received in damaged condition, the carrier should be notified immediately. Claims for such damage should be filed with the carrier involved in accordance with the F.O.B. point.

Headquarters:  
Valcom, Inc.  
5614 Hollins Road  
Roanoke, VA 24019-5056  
Phone: (540) 563-2000  
Fax: (540) 362-9800

#### TABLE 1 - TROUBLESHOOTING CHART

Symptoms	Solutions
1. Red power reversal LED is lit.	A. Reverse power connections to pins 29 and 30.
2. Will not trip ringing.	A. Verify -24VDC on pins 29 (+) and 30 (-). B. Verify ring voltage is present on pins 16 and 17 (75VAC minimum).
3. No output from amplified speaker assemblies.	A. Listen (using a lineman's test set) for audio on 8 Ohm output (pins 8 and 9). B. Verify -24VDC to speakers. Remember, GND is (+), -24VDC is (-).
4. Unit will never release.	A. Refer to the appropriate connection Figure and verify the dip switches are set properly.
5. All call does not work.	A. Verify connections according to Figure 6. B. Verify "all call out" of master unit is connected to "all call in" of all other units. C. Verify 8 Ohm output of master unit connected to "all call audio in" of all other units. D. Verify proper voltage and polarity on pin 29 (+) and 30 (-) of master unit. E. Verify ring voltage is present on pins 16 and 17 of master unit when all call number is dialed.