



The 100A Analog Interface Module

(for connection with the 6416D+M and 6424D+M Telephones)

Installation and User Instructions

[This module meets U.S. Analog Telephone Interface Requirements.]

Document Ordering No. 555-233-707
Comcode 108241951
Issue 1
June 1999

----- INSTALLATION -----

1

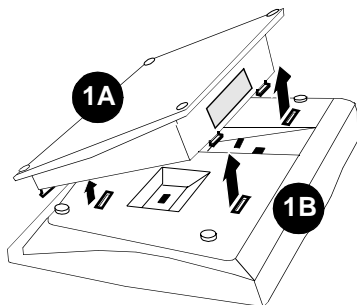

Remove the desktop stand (1A) from the bottom of the telephone (1B). Push inward on the top of the stand until you can lift the top of the stand from the tab slots on the telephone.

2

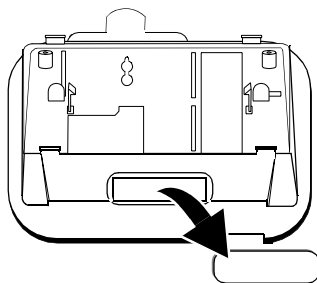

Remove the cover from the module opening in the desktop stand.

Hint: Keep the module opening cover nearby for later use. See Step 8 for instructions on storing the cover.

3

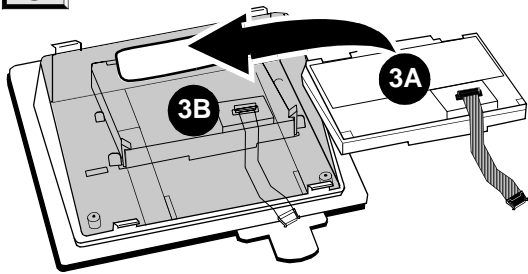

Install the module (3A) in the desktop stand (3B). Push down until you hear the module snap in place.

Hint: The analog adjunct jack on the module should be pointing toward the module opening on the desktop stand and the cable on the module should be facing up.

4

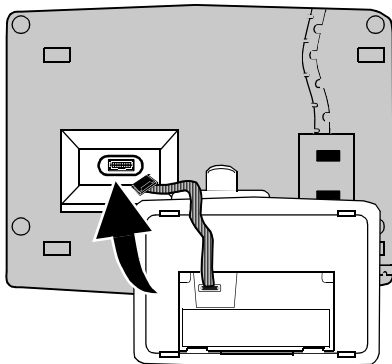

Carefully align the module ribbon cable to the mating receptacle on the bottom of the telephone and insert slowly.

5

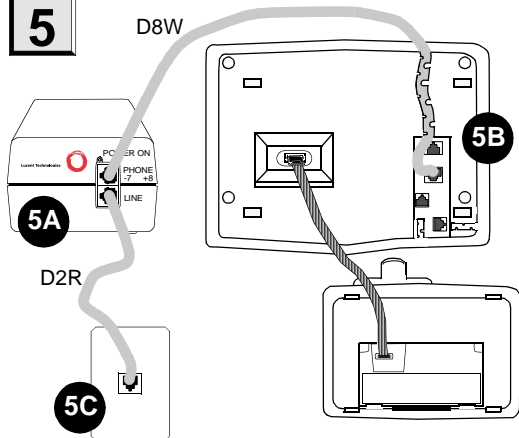

Connect the stand-alone local auxiliary power supply (5A). With the D8W cord, connect the auxiliary power supply (the PHONE jack) to the Line jack on the telephone (5B). Then, connect the power supply (the LINE jack on the power supply) to a wall jack (5C).

Hint: The 100A module requires auxiliary power, and you must use an 8-wire line cord from the telephone to the power supply.

6

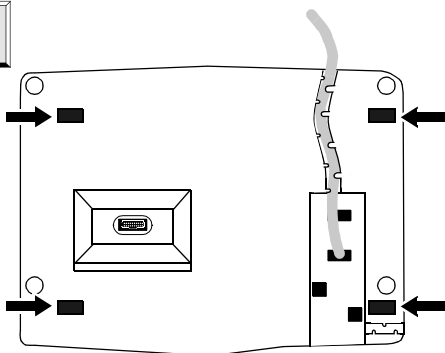

Replace the stand and module by lowering the desktop stand onto the bottom of the telephone. The tabs on the stand must snap into the appropriate slots on the bottom of the telephone. (These slots are marked with arrows in the accompanying drawing on the left.)

7

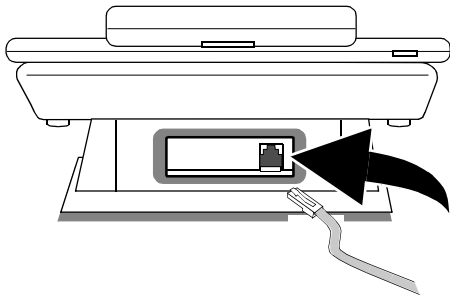

Connect the analog adjunct such as a modem, fax machine, or analog telephone to the module.

8

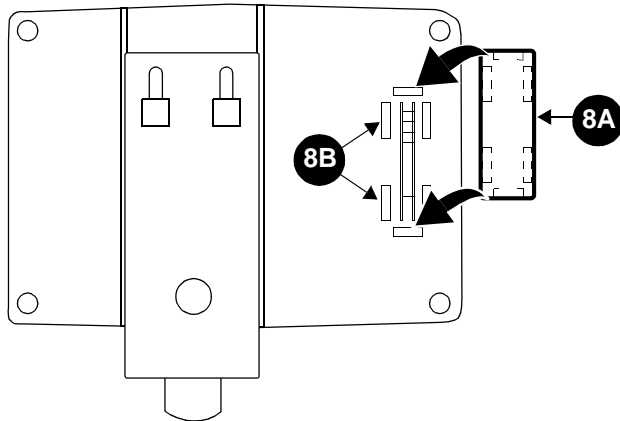

The desktop stand has slots in which you can store the cover (8A) you removed from the module opening (see Step 2) in case you need to reinsert the cover at a later time. (8B shows the location of the storage area.) Snap the tabs on the cover into the slots provided on the desktop stand.

----- The 100A Analog Interface Module Option Switches -----

On the bottom of the installed 100A module, there are two option switches, shown at the right.

1. SET THE OPTION SWITCH ON THE LEFT TO EITHER 1 OR 2.

- When the Option switch on the left is set to 1, the telephone and the Analog adjunct *share the same line*. Therefore, only one device, the telephone handset OR the telephone built-in speakerphone OR the Analog adjunct can transmit on the same line at one time.

If the telephone is connected to a DEFINITY switch prior to Release 8.1, you **MUST** use Setting 1; that is, you **CANNOT** use Setting 2.

- When the Option switch on the left is set to 2, you can use a second line for transmission on the analog adjunct, a line that is independent of the telephone. When the second line is used, the telephone and the analog adjunct can use independent lines *simultaneously*.

If the 100A module is installed on a 6416D+M or 6424D+M telephone connected to a DEFINITY switch Release 8.1 or later, you can set the switch on the left to Setting 1 or 2.

2. IF THE OPTION SWITCH ON THE LEFT IS SET TO 1, YOU MUST SET THE OPTION SWITCH ON THE RIGHT TO EITHER FAX OR

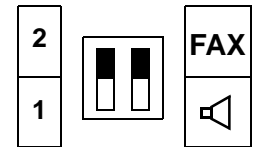

The switch on the right allows you to choose whether the analog adjunct, when active, will be interrupted when you pick up the handset or turn on the built-in speakerphone. Set the option switch on the right according to the analog device that is connected with the telephone.

- The  option means that the analog adjunct will be interrupted. **Use this option for adjunct speakerphones or answering machines or an analog telephone.** If an attached speakerphone does not recognize a far end disconnect signal, you may have to manually turn off the speakerphone.
- The **FAX** option does not interrupt the analog adjunct. **This option is useful for fax machines and modems.**

NOTES: The system manager may choose to administer a feature button on the telephone to provide you visible indication of the status of the second line used on Setting 2. Then, whenever the analog adjunct is active on the second line, the green light next to the button goes on.

Switch translation changes may be needed if the 100A module is optioned for Setting 2. See your system manager.

----- General Information on the 100A Module -----

- The 100A module can be installed in the desktop stand of the **Modular 6416D+M (6416D02A) and 6424D+M (6424D02A) telephones** for increased set functionality.
- Through a **6-position RJ11-type jack**, the 100A module provides connection between these 6400 Series telephones and analog adjuncts such as **answering machines, fax machines, modems, analog speakerphones, and TDD machines** commonly used by the hearing impaired.

NOTE: The 100A module is capable of supporting V.90 Series modem communication rates. However, the maximum modem communication rate cannot be guaranteed because it is limited by the quality of the end-to-end channel. Also note that only DTMF (Dual Tone Multi-Frequency) dialing is supported by the 100A module.

- **The 100A module will work ONLY if it has auxiliary power.** When the auxiliary power source is turned on, the 100A module will automatically power up.
- **You MUST use an 8-wire line cord from the telephone to the power supply.** If you have only a 2-wire line cord, replace it with the 8-wire cord that comes with the power supply.
- **If there is a power outage and the auxiliary power source shuts off**, the telephone will continue to work, but the 100A module will NOT function.
- This 100A module has been specially designed so that the voice quality of the analog adjunct connected to the module is equivalent to the performance of the analog adjunct when it is connected to an analog port on a DEFINITY® switch. (This is true **only for switches which use United States transmission levels.**)
- The 100A module also has a special detector which senses if the analog adjunct is on-hook or off-hook, and the module, therefore, is **able to disconnect the analog adjunct at the end of a call.** However, whether the analog adjunct responds to a request to hang up depends on the design of the analog adjunct.
- The manner in which the telephone and the analog adjunct interact depends on the switch release to which your telephone is connected. (Your system manager can give you more information about the switch release.)
 - **On DEFINITY Enterprise Communications Server (ECS) releases prior to Release 8.1**, the analog adjunct shares the telephone line with the voice terminal. Therefore, while the telephone is being used, you *cannot* use the analog adjunct at the same time, or vice versa.
 - **On the DEFINITY ECS Release 8.1 and later**, the telephone and the analog adjunct can be assigned separate telephone lines, and thus the voice terminal and analog adjunct can be used *simultaneously*.



----- Troubleshooting -----

NOTE: The telephone display provides visible indication whether the module has power. A “+” appears in the upper right of the time/date display if there IS power to the module. A “-” appears on the time/date display if the module does NOT have power.

Problem	Solution
There is no power to the module.	<ol style="list-style-type: none"> 1 Check all the cords to make certain they are securely connected at both ends. 2 Make certain that the power cord connecting the auxiliary supply to the telephone is an 8-wire cord.
The module does not have dial tone.	<ol style="list-style-type: none"> 1 Check that the module has power. If the “-” indication appears in the upper right of the time/date display, check the items below. 2 Check all the cords on the module and the auxiliary power supply to make certain they are securely connected at both ends. 3 Make sure that the switches on your module are set correctly. Use the section titled, “The 100A Analog Interface Module Option Switches” earlier in these instructions.

Problem	Solution
The module does not have dial tone. (continued)	<p>4 Check with your system manager to make certain that the telephone has been administered correctly.</p> <p>5 Connect the module in question with another 6416D+M or 6424D+M set which has a working module. If the module being tested still does not work, it is faulty.</p> <p>If the module in question works in the other telephone, try the working module taken from the other telephone and connect it with the original telephone. If this module does not work, the telephone is faulty.</p>
The telephone has no dial tone.	<p>1 While on-hook, press Trnsfr to initiate a self-test. If the lights next to the buttons on the telephone do not go on steadily, the voice terminal is not powered from the PBX.</p> <p>2 If the self-test fails, next, make sure the handset and line cords at your voice terminal are securely connected at both ends.</p> <p>3 If the self-test works but there is still no dial tone, check with your system manager to be sure your voice terminal is administered correctly.</p> <p>4 If the set is administered correctly but there is still no dial tone, remove the module. If the telephone, without the module, has dial tone, connect the module in question to another working 6416D+M or 6424D+M set.</p> <p style="padding-left: 20px;">a. If the module works in the new telephone, the telephone to which the module was originally connected is faulty.</p> <p style="padding-left: 20px;">b. If the new telephone, once the module has been connected, does not work, the module is faulty.</p> <p>5 If the original telephone, without the module, still does not work, find a working telephone of the same type as the original. Unplug this telephone from its modular wall jack. Plug your telephone into that jack and check if it gets dial tone.</p> <p>6 If the original telephone still does not work, plug the working telephone (of the same type) into your modular wall jack. If the working telephone has dial tone, your own telephone is faulty. See your system manager.</p>

The following problems may occur with some external speakerphones connected to the 100A module. These problems may occur with other equipment as well.

The attached analog equipment does not automatically go on-hook when the far end disconnects.	The attached analog equipment does not detect the "disconnect" signal sent from the 100A module. You must manually turn off (place on-hook) your analog equipment.
The attached analog equipment does not automatically go on-hook when you lift the handset of your 6400 Series modular telephone.	If the option switch labeled  and FAX is set to  , then the attached analog equipment does not detect the "disconnect" signal sent from the 100A module. You must manually turn off (place on-hook) your analog equipment.
You cannot originate or answer calls at your 6400 Series modular telephone OR Your 6400 Series modular telephone appears "dead" because no red light is next to one of the call appearance buttons.	The attached analog equipment may be off-hook because it does not detect the "disconnect" signal sent from the 100A module. You must manually turn off (place on-hook) your analog equipment.

IMPORTANT USER SAFETY INSTRUCTIONS

The most careful attention has been devoted to quality standards in the manufacture of this module. Safety is a major factor in the design of product. But, safety is YOUR responsibility too.

Please read carefully the helpful tips listed below and on the next page. These suggestions will enable you to take full advantage of this module. Then, retain these tips for later use.

WARNING:

This module and the telephone to which it is connected are NOT for residential use. They are for business systems applications ONLY. Use in a residential environment could result in an electrical short circuit when the telephone wiring is set up to provide other applications, for example, for appliance control or power transformers. The AC power used in these applications may create a safety hazard by placing a direct short circuit across the telephone wiring.

Use

When used with your telephone equipment, the following safety precautions should always be followed to reduce the risk of fire, electric shock, and injury to persons.

- Read and understand all instructions.
- Follow all warnings and instructions marked on the telephone and module.
- The module and the telephone can be hazardous if immersed in water. To avoid the possibility of electric shock, do not use them while you are wet. If you accidentally drop either of these pieces of equipment into water, do not retrieve it until you have first unplugged the line cord from the modular wall jack. Then, call service personnel to ask about a replacement.
- Avoid using the telephone and the connected module during electrical storms in your immediate area. There is a risk of electric shock from lightning. Urgent calls should be brief. Even though protective measures may have been installed to limit electrical surges from entering your business, absolute protection from lightning is impossible.
- If you suspect a natural gas leak, report it immediately, but use a telephone away from the area in question. The telephone's electrical contacts could generate a tiny spark. While unlikely, it is possible that this spark could ignite heavy concentrations of gas.
- Never push objects of any kind into the equipment through housing slots since they may touch hazardous voltage points or short out parts that could result in a risk of electric shock. Never spill liquid of any kind on the telephone and the connected module. If liquid is spilled, however, refer servicing to proper service personnel.
- To reduce the risk of electric shock, do not disassemble the module or the telephone. There are no user serviceable parts. Opening or removing covers may expose you to hazardous voltages. Incorrect reassembly can cause electric shock when the telephone and the module are subsequently used.
- The interface provided by this module is for indoor use only. DO NOT attempt to connect this module to equipment used outdoors.

Service

1. Before cleaning, unplug the telephone and any adjuncts from the modular wall jack. Do not use liquid cleaners or aerosol cleaners. Use a damp cloth for cleaning.
2. Be sure to refer servicing to qualified service personnel when these conditions exist:
 - If liquid has been spilled into the telephone or the module.
 - If the telephone or module has been exposed to rain or water.
 - If the telephone or module has been dropped or the housing has been damaged.
 - If you note a distinct change in the performance of the telephone or the module.

SAVE THESE INSTRUCTIONS



When you see this warning symbol on the product, refer to this instructions booklet packed with the product for more information before proceeding.

OTHER INFORMATION

NOTICE

While reasonable efforts were made to ensure that the information in this document was complete and accurate at the time of printing, Avaya can assume no responsibility for any errors. Changes or corrections to the information contained in this document may be incorporated into future issues.

TO ORDER COPIES OF THIS DOCUMENT

Contact: Globalware Solutions
200 Ward Hill Avenue
Haverhill, MA 01835 USA
Voice 1 800 457-1235
International Voice +1 410 568 3680
Fax 1 800 457-1764
International Fax +1 410 891 0207

Order: Document No. 555-233-707
Issue 1, June 1999

For more information about related documents, see *Business Communications Systems Publications Catalog*, 555-000-010.

TRADEMARKS

DEFINITY is a registered trademark of Avaya Inc.

US ANALOG INTERFACE REQUIREMENTS

The 100A module meets US Analog Telephone Interface Requirements.

HEARING AID COMPATIBILITY

These telephones are Hearing Aid Compatible (HAC) and thus have "HAC" printed on them.

ACKNOWLEDGMENT

This document was prepared by the BCS Product Publications Department, Avaya Inc., Middletown, NJ 07748-9972.