

# Model 390 User Guide - English

Congratulations on your purchase of a Model 390 telephone! The Model 390 boasts several timesaving and advanced features, including:

- a large 8-line display;
- a 200 entry Directory and 100 entry Callers List;

- a speakerphone for handsfree calls;
  - access to advanced services.
- Use this user guide to learn more about the Model 390's features.

## Basic Features and Functions

**Hold**

Pressing Hold puts a handset or Handsfree call on hold.

- You can hang up the handset without losing the call.
- The display will show the message **Call is on hold**.
- The telephone light will flash.
- To retrieve the call, lift the handset or press **Hold** again. You can also press **Speaker** to retrieve a Handsfree call.
- A call is taken off hold automatically after 15 minutes. If the handset is on the phone, the call will be disconnected. If the handset is off, the caller will be able to hear you again.

**Redial**

Pressing Redial opens the Redial List, which stores the last 10 numbers you dialed. See the section "Using the Redial List" for more information.

**Goodbye**

Pressing Goodbye ends an active call. Goodbye exits an open list, such as the Directory or Callers List, but if a call is active when the list is open, it will also end the call. It will not hang up a call that is on hold. Take the call off hold before pressing **Goodbye**.

**Options**

The options button lets you access six options to customize your telephone. See the section "Customizing your phone" for more information on the following options:

1. Language
2. Time / Date
3. Set ring tone
4. Clear Message Waiting
5. Area code
6. Contrast level

Pressing opens the Directory, which can store up to 200 names and numbers in alphabetical order. See the section "Using the Directory" for more information.

Pressing and lets you move between screens when you are using services. These buttons also let you scroll through menu selections, such as the Options List. When you are editing entries on the display, deletes a character or number, and adds a space when entering or editing names.

Softkeys let you select commands displayed on the screen. See "How do I use softkeys" for more information.

Pressing the volume button adjusts the receiver, speaker, and ringer volume.

- To adjust the ringer volume, leave the handset in the cradle and press the volume button while there is no active call. There are 8 settings for the ringer – the display will temporarily indicate the current ringer volume setting.
- To adjust the handset volume, lift the handset and press the volume button while you are on a call. The handset will return to the default volume after you hang up.
- To adjust the speaker volume, press the volume button while the speaker is activated (activate the speaker by pressing **Speaker**). The speaker will remain at this volume until it is adjusted again.

**Speaker**

Pressing Speaker activates Handsfree so you can listen and talk without lifting the handset. If the handset is off hook, pressing **Speaker** alternates between Handsfree and the handset. If the handset is on the phone during a Handsfree call, pressing **Speaker** disconnects the call. **Mute** turns muting on and off for Handsfree calls.

**Mute**

Pressing Mute puts the current call (on the handset or Handsfree) on mute. The display will show **Microphone muted**. When a Handsfree call is muted, the speaker light blinks. To take a call off mute, press **Mute** again.

The Speaker light turns on when the speaker and microphone are activated. It flashes when the microphone has been muted.

**Services**

Pressing Services opens a list of Services scripts that are stored in memory. See the section "Services" for more information on downloading and using services.

**Copy**

Pressing Copy copies a displayed number into the Directory.

Pressing opens the Callers List, which stores the last 100 callers. See the section "Using the Callers List" for more information.

The red **telephone light** shows when you have incoming calls, a message, or a call on hold. A message is displayed when the light is on. See the section "Status lights" for more information.

**Flashing light** – call is on hold, a message is waiting, or a call is ringing.

**Steady light** – another phone is using the line. The display shows **Extension in use**.

## Installation

Your Model 390 telephone can be installed on a desk or mounted on the wall.

### 1. Connect the handset cord:

Turn the telephone over and locate the handset jack marked . Insert one end of handset cord into the jack until it clicks into place. Then route the handset cord through the groove as shown in the illustration below.

Attach the handset to the other end of the handset cord.

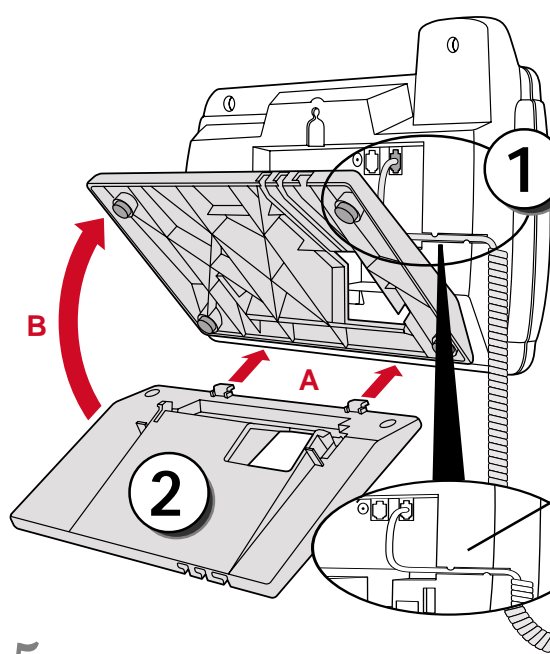

### 2. Attach the stand:

**If you plan to mount the phone on the wall, you do not need to attach the stand; skip this step.** If you plan to use the phone on a desk, attach the stand by inserting the tabs on the stand (marked with ) into the slots on the bottom of the telephone (A). For a higher viewing angle, use the slots marked . For a lower viewing angle, use the slots marked . Then rotate the stand towards the phone until it snaps into place (B).

### 3. Connect the cords:

**If you attached the stand to install the phone on a desk,** route both the phone cord and power adapter cord through the opening in the stand. Insert the phone cord into the slot on the back of the telephone marked until it clicks into place. Insert the power cord into the power jack marked .

**Note:** You should connect the power adaptor to a surge protector or power bar.

### 4. Press the cords into the grooves:

Press the cords into two of the grooves provided on the bottom of the stand. This will allow the stand to sit flat on a desk surface.

#### Install parts:

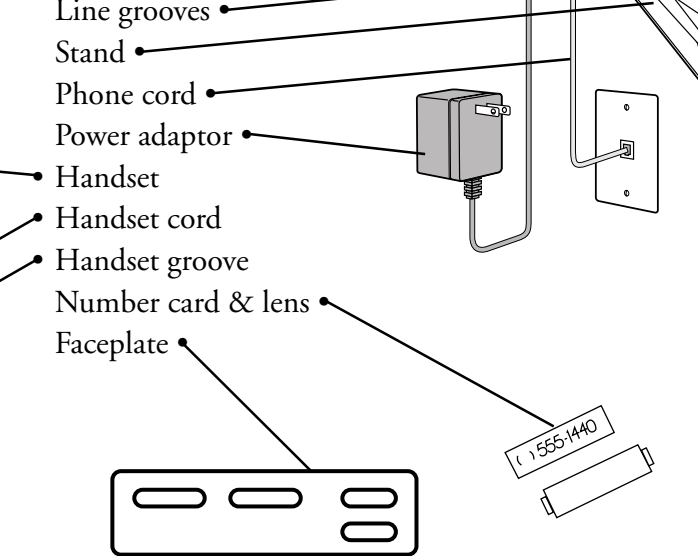

### 5. Install the phone:

**If you have installed the stand and are using the phone on a desk:**

Simply turn the telephone over so it rests on the stand. Connect the phone cord to a phone jack and plug the power adapter into a power outlet.

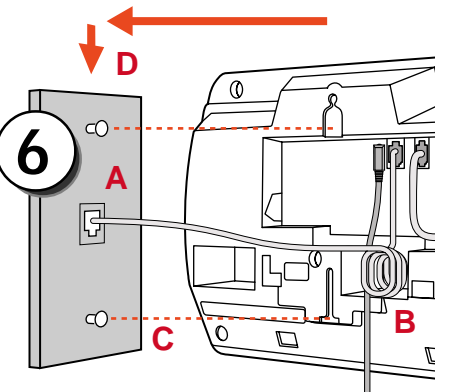

### 6. Install on a wall:

**To install the Model 390 on a wall:**

Connect the cord to the wall jack (A). Coil the phone cord into the space provided on the back of the phone (B). Then align the telephone so the hooks on the wall plate (C) align with the wall-mount slots on the back of the phone, as shown here. Push the phone onto the pegs, then slide it down until it is secure (D). Plug the power adaptor into a power outlet (E).

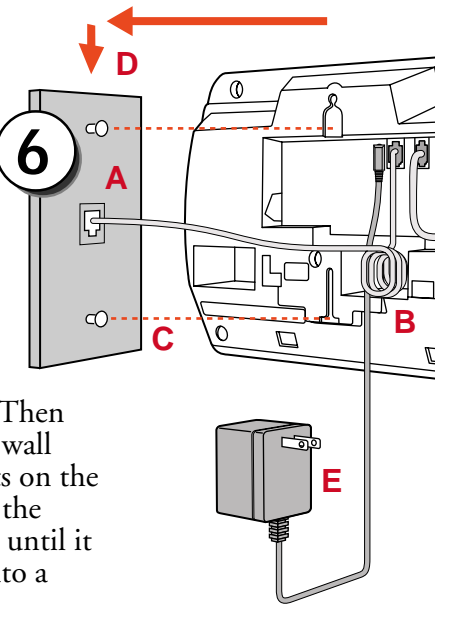

**Note:** You may wish to purchase a short phone cord from a local supplier for a wall installation.

### 7. Insert number card:

Write your telephone number on the number card, and place it into the card slot on the telephone, located under the mouthpiece in the handset cradle. Gently bend the clear plastic lens into the slot, over the number card.

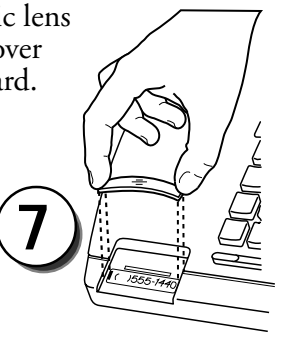

### 8. Insert Faceplate:

Snap the faceplate into the recess provided above the dial pad. Slide the tab on the left-hand side of the faceplate into the slot. Then press on the right-hand side of the faceplate to snap it into place.

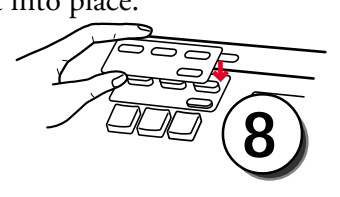

### 9. Customize the telephone:

Follow the instructions in the section "Customizing your phone" to customize your Model 390 telephone.

## Customizing your phone

There are six configuration options, accessed by pressing the **Options** button.

### SETTING your Options:

1. Press **Options** to enter the Options List.
2. Use and to scroll through the list of six options.
3. Press the **Show** softkey to configure an option.
4. Use the softkeys to change a selected option.
5. Press the **Done** softkey at any time to exit the option, or press **Options** to exit the Options list.

The following six options may be changed on the Model 390:

1. **Language** – Select a language for the display prompts (English, French, or Spanish).
2. **Time / Date** – Use this option to change the time and date setting on the display. Press the appropriate softkey to increase that item by 1. For example, press the **Hour** softkey to increment the hour from 1 to 2. **Note:** The time and date are automatically set when the phone receives its first Caller ID\* call.

3. **Set ring tone** – Press the **Change** softkey to select one of four ring tones.
4. **Clear Msg. Wtg.** – Sometimes the **Message Waiting** prompt will appear and the light will flash when there are no messages waiting on your Voice Mail® service. When in this option, select the **Clear** softkey to clear the prompt and flashing light. The light will flash again when there are new messages waiting.
5. **Area Code** – In some locations, you cannot dial a local number using the area code. By default, incoming calls are recorded with area codes in the Callers List. This option allows you to enter up to three local area codes to be removed from incoming calls. Press the **Change** softkey to enter an area code.
6. **Contrast Level** – Use the **Change** softkey to cycle through 8 contrast settings, which brighten or darken the display.

## Notes

This space is provided so that you may make notes while installing and using your Model 390 telephone.

## Unpacking the phone

When you unpack your telephone, you should ensure that you have all of the following items:

- telephone
- handset
- handset cord
- phone cord
- power adaptor†
- stand
- documentation kit
- plastic faceplate

In the documentation kit, you will find:

- this user guide
- a paper number card and plastic lens
- a regulatory sheet

If any part is missing, contact the supplier of your telephone.

†The power adaptor is 16 VAC, 250mA – please see the regulatory sheet for safety instructions regarding the power adaptor and operation of the telephone.

## How do I use softkeys?

This telephone uses softkeys to give you commands to choose from. Each choice corresponds to the button next to it. In this illustration, the user is selecting **NextSpace** to insert a space. Commands will change depending upon the action you are performing.

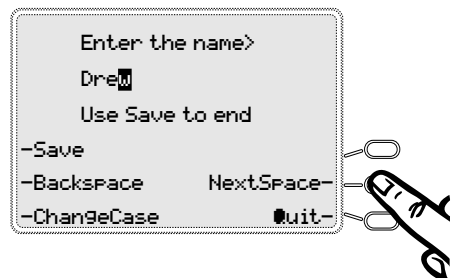

## Emergency service feature





The Model 390 will provide telephone service during a power failure. However, only the dial pad, ringer and handset will function. If you are on a handset call during a power interruption, the Model 390 will keep the call, although the display will not work while the power is off. Handsfree calls will not be re-established during a power interruption.

## Using the Directory

The Directory can store up to 200 names and numbers, which are displayed in alphabetical order.

**Tip:** Store all your Directory contacts the same way, either first name first, or last name first. This will make it easier to find names and numbers.

### ADDING a name and number to the Directory:

1. Press the Directory button .
2. Press the **AddNew** softkey.
3. Enter the number using the dial pad. You can enter up to 24 digits. Hyphens will be automatically added. If you need to enter a pause (between your voice mail number and password, for example), press the **Pause** softkey. The pause icon  will appear. To program a number that uses Flash, press the **Flash** softkey where it is required in the number. The Flash icon  will appear. Press the **Backspace** softkey or  to erase a number.
4. Press the **Save** softkey.
5. Enter a name using the letters on the dial pad. See the following instructions “**Entering Letters and Characters**” to enter names using the dial pad. The name can have up to 16 characters, including spaces.

Press the **NextSpace** softkey or  to move to the next letter or add a space.

Press the **Backspace** softkey or  to erase a character.

6. Press the **Save** softkey. The new entry now shows on the display.



**Note:** You can also copy an entry from the Callers List to the Directory using the  button, before or after you have changed it.

### ENTERING Letters and Characters

You can enter characters using the telephone's dial pad. To enter a letter, press the key with that letter on it. If the letter is the second one on that key, press the key twice. For example, to enter 'R', press  three times.

The cursor will advance to the next space after a delay of 2 seconds or if you press a different key.

To change the case of a letter, press the **ChangeCase** softkey, and then enter the letter. By default the first letter of a word or name will be capitalized, and the letters following will be lower case.

Special characters are entered by pressing the  and the  keys. Characters will appear in this order:

: \*, ( ) ^ ` . - - 1.







: # / \ \ .

## Using the Callers List

The Callers List records the last 100 callers', in the order they called. The telephone display will indicate when there are new callers.

When the Callers List is full, new callers are added to the list, and the oldest callers are deleted. In the Callers List you will see the message **XX New caller(s)**, **XX Call(s)** **bumped** on the display.

### VIEWING the Callers List:

1. Press the Callers button .
  2. Press  and  to move up and down in the Callers List. Hold either key down to scroll continuously. You can also press the **Resume** softkey to see the last caller you viewed the last time you entered the Callers List.
  3. Press the Callers button , the **Quit** softkey, or  at any time to leave the Callers List.
- Note:**  will also hang up a caller if you are on a call.

### CALLING an entry in the Callers List:

1. Find the entry you would like to call in the Callers List.
2. Lift the handset to dial the number, or press the **Dial** softkey or  to dial the number using Handsfree.

### COPYING from the Callers List to the Directory:

When the number is displayed in the Callers List, press . The display will show **Saved: Directory**. If the entry in the Callers List does not have a name (i.e. if the name is listed as **Unknown** or **Private**), you will be prompted to enter a name. You can edit a number in the Callers List and then copy it to the Directory.

### CHANGING a number in the Callers List before dialing:

**Tip:** If you have to frequently remove area codes to return local calls, you should use the Area Codes option and add your local area code(s).

**Note:** The Callers List does not save changes. If you plan to dial the number again, copy it to the Directory and change it there.

1. Find the caller in the Callers List you wish to dial.
2. To add digits, use the dial pad.
3. To delete digits, press the **EditNum** softkey to begin editing. Use the dial pad to add digits.
4. Lift the handset to dial the number, or press the **Dial** softkey or  to dial the number using Handsfree.

### DELETING an entry in the Callers List:





1. Find the entry you would like to delete in the Callers List.
2. Press the **Delete** softkey.
3. Press the **Delete** softkey again to confirm. The display shows **Item is erased**.

### DELETING all entries in the Callers List:



1. Press the Callers button .
2. Press the **DeleteList** softkey.
3. Press the **Delete** softkey to confirm. The display shows **Callers list is empty**.

\* You must subscribe to a Caller ID service for this feature to work. Consult your local telephone company for information.

### FINDING entries in the Directory:

1. Once in the Directory, press  to scroll down and  to scroll up one listing at a time. Hold either key down to scroll continuously.
2. Press a dial pad key to see listings that start with that letter. For example,  takes you to the first “J” listing,  takes you to the first “K” listing.

### CHANGING entries in the Directory:

1. Find the entry you would like to change.
2. Press the **Change** softkey.
3. To change the number, use the **Backspace** softkey or  to erase digits. Use the dial pad to add digits. Use the **Pause** softkey to insert a 2 second pause. The pause icon  will appear.
4. Press **Save** to move to the name.
5. To change the name, use the **Backspace** softkey or  to erase letters. Use the dial pad and the **NextSpace** softkey to add letters. Press the **ChangeCase** softkey to switch between upper and lower case.

6. Press **Save** to save changes.

### COPYING from the Callers List, the Redial List, or the Display to the Directory:

1. Open the Callers List, Redial List, or answer a call.
2. When the number is displayed on the screen, press . If the entry includes a name and number, the display will show **Saved: Directory**.
3. If the entry is a number only (such as in the Redial List), you will be prompted to enter a name. Once you've pressed the **Save** softkey to save the name, the display will show **Saved: Directory**.

## Using Services

The Model 390 telephone allows you to access enhanced telephone company subscription features and services, which can include home banking, catalogue shopping, restaurant guides, and voice mail.

Services may be free or may have a subscription cost. Contact your telephone company for information.

The Services menu shows the services that require subscription. Before selecting a service, you must download the service into your telephone. Contact your telephone company for information on downloading services in your area. Downloading a service is as simple as dialing the subscription number and following any voice prompts.

Your phone may be capable of automatically dialing out to update your subscribed features and services. For more information on this ability, contact your telephone company.

Some services may be available by dialing them directly. You do not have to download these services, but you may wish to save them in your Directory.

**Note:** Some options, such as the call timer, may be disabled when you are using a service.

### DIALING from the Directory:

1. Find the entry you would like to call in the Directory.
2. Lift the handset to dial the number, or press the **Dial** softkey or  to dial the number using Handsfree.

### DELETING an entry in the Directory:

1. Find the entry you would like to delete.
2. Press the **Delete** softkey.
3. Press the **Delete** softkey again to confirm.

### DELETING all entries in the Directory:



Once you have deleted the Directory, you cannot get entries back. You can protect the Directory by locking it.

To permanently delete all entries in the Directory:



1. Press the Directory button .
2. Press the **DeleteList** softkey.
3. Press the **Delete** softkey to confirm.

### LOCKING the Directory:







You can lock the Directory so that entries cannot be deleted or changed. You cannot add entries to a locked directory.

1. Press .
2. Press .
3. Press . The display shows **Directory locked**.

To unlock the Directory:

1. Press .
2. Press .
3. Press . The display shows **Directory unlocked**.

### ACTIVATING services:

1. Dial the number provided by your telephone company and follow the prompts.
2. Once you have successfully downloaded the services of your choice, press the  key. The Services menu appears.
3. Use the  and  keys to move the  indicator to the Service you want to select.
4. Press the **Select** softkey to activate the service next to the  indicator.
5. Once you have connected to the service, follow the instructions on the display.
6. To exit a service session, press the **Quit** softkey,  or  to leave the Services List.

### DEACTIVATING services:





You may deactivate a service by contacting your telephone company. You can delete a downloaded service in the Services menu by selecting it and pressing the **Delete** softkey. The service will appear as **<deleted>**.

If you download another service, it may overwrite any service displayed as **<deleted>**.



## Icons

The display uses icons to convey information about calls, Directory entries, Callers, and services.



### Icons in the Callers List:

-  You are viewing the Callers List.
-  You answered the call when it came in.
-  You did not answer the call when it came in.
-  You were on another call when this call came in.
-  You have returned the call from the Callers List.





### Icons in the Directory:

-  You are viewing the Directory.
-  You pressed the **Flash** softkey, or Flash has been programmed into a number.
-  You pressed the **Pause** softkey or a pause (which is about 2 seconds) has been programmed into a number.

### Other List Icons:

-  You are viewing the Redial List.
-  You are viewing the Options List.

### Icons in the Services List:

-  You are viewing the Services list.
-  Press  or  for more information.
-  Service information is being downloaded to your telephone.

## Status lights

### Speaker Light

- Speaker light is on: a call is on Handsfree (speaker).
- Speaker light flashes and the display shows **Microphone muted**: a call is muted. Press  to take the call off mute.



### Telephone Light

- Light flashes and the display shows **Call is on hold**: a call is on hold. Press  or lift the handset to take the call off hold.
- Light flashes and the display shows **Message Waiting**: a message is waiting for you at your message or voice mail service.
- Light flashes quickly and the ringer sounds: you have an incoming call.
- Light is on and the display shows **Extension in use**: an extension telephone is using the line. This message also appears when the telephone is not properly connected to a phone line.





\* You must subscribe to a Visual Message Waiting service for this feature to work. Consult your local telephone company for information.



## Advanced Features

### PREDIALING a number:

Predialing lets you view a number before you dial. Enter the number using the dial pad and before lifting the handset. Use the **Backspace** softkey or  to correct any errors. To dial the number, lift the handset, press the **Dial** softkey, or press .

### HANDSFREE Calling:

The Handsfree feature allows you to speak to someone without using the handset. To dial using Handsfree, enter a number and then press  or the **Dial** softkey. To answer using Handsfree, press  when a call is ringing. To switch between Handsfree and the handset when the handset is off hook, press . When the handset is on hook, press  to disconnect a Handsfree call.

When Handsfree is on, the speaker light turns on. When the speaker light is on, press  at any time to mute Handsfree. The speaker light will flash and you will hear the caller, but they will not hear you. To switch between Handsfree and mute press .

### TIMING a call:

When you make or answer a call, the Timer shows the elapsed time of the call.

### USING Flash:

The **Flash** softkey allows you to access telephone company subscribed services, such as call waiting and three-way calling. These services vary from area to area, so contact your telephone company for instructions on using available services and your Model 390 telephone. If these instructions say to press the “hook-switch” or “receiver button,” press the **Flash** softkey.

### EXTENSION IN USE:

The **Extension in use** prompt appears on the telephone display and the light turns on when someone uses another telephone on the same line.



This message also appears when the telephone is not properly connected to a phone line.

## Display prompts

Instructions and information are displayed on the large screen. If you are unsure what a certain prompt means, find it here, or see the **Troubleshooting** section for additional information.

**Directory is full** – The Directory has 200 names and numbers in it. You need to delete an entry before you can add another entry.

**Directory locked** – The Directory has been locked, and you cannot edit, add, or delete entries. See the section “**Using the Directory**” for more information.

**Message Waiting** – Check for new messages in your Voice Mail service. **More**  – Press  to see other prompts.

**Private name** or **Private Number** – The caller has requested that the name (or number) not be shown.

**Ringer is OFF** – No audible ringing. To turn the ringer on again, press the right side of .

**Unknown name** or **Unknown number** – The telephone company is unable to provide the name (or number) of the caller.



**XX New caller(s)** – XX new calls have been added to the Callers List since you last checked it.

**XX Call(s) bumped** – XX callers have been deleted from the Callers List to make room for new callers.

## Using the Redial List

The Redial List records the last 10 numbers you dialed.

### REDIALING a number:

1. Press  to view the Redial List.
2. Use the  and  keys to move the cursor to the number you want to dial.

## Troubleshooting

### What are services, and how do I use them?

Services are provided by your telephone company, and include basic features such as Caller ID\*. Other services can be accessed through the  key, and may include services such as Call Forwarding\* and Voice Mail\*. Before using your services, you must activate them by contacting your local telephone company. See the section “**Using Services**” for more information.

### I'm having trouble with services I have subscribed to – how do I get help?

Usually your telephone company supplies a special number to call for activation of your services. When you call this number, you must follow the recorded instructions carefully. This allows the telephone company's system to recognize your phone and customize it with the services you have subscribed to. If you have any activation problems call your local telephone company.

### Why are there no prompts on the screen when a Call Waiting call comes in?

You must subscribe to Call Waiting Identification\* from your telephone company.

### Why is the light not coming on with a new Voice Mail Message?

You must subscribe to the “Visual” Message Waiting\* service from your telephone company for this function to work.

### Why don't numbers I return from the Callers List connect?

Incoming calls are recorded with the area code attached, whether they are long distance or local calls. You must remove the area code from local calls in order to call from the Callers List, or use the Area Code option in the options list to have local area codes automatically removed. See the section “**Customizing your phone**” for information about the Area Code option. Alternatively, you may need to add ‘1’ before long distance numbers in order to dial long distance.

### Why is my display blank?

Ensure that the power adaptor is fully plugged into the electrical outlet, and that the outlet is supplying power (you can test this with another electrical device, such as a lamp).

### How do I set the time and date?

If you subscribe to the Caller ID\* service, the first incoming call will update the phone with the correct time & date. Otherwise, use the Time/Date option in the options list to manually set the time and date.

### Why can I only see 4 options when the user guide says there are 6?

The telephone screen will only show 4 options at a time. To see more, press the down arrow button .

\* These services may have different names in your area. Contact your telephone company for details.